

Connecting dimensions, valid for article numbers A_00037-02 and A_00088-03

m= kg	A	p= bar
proj. storage surface = m ²		v= l/min
First angle projection	P= kW	U= V / Hz / Ph
	U=	I _{max} = A

12 11 10 9 8 7 6 5 4 3 2 1

H
G
F
E
D
C
B
A

- All fastening holes $\varnothing 13,5$ mm for screws M12 (DIN ISO 4014/4017 -8.8) without washers. Fastening holes are coloured red.
- Drilling holes for locating pins are filled red. Recommended dimensions of locating pins: $\varnothing 12$ h6

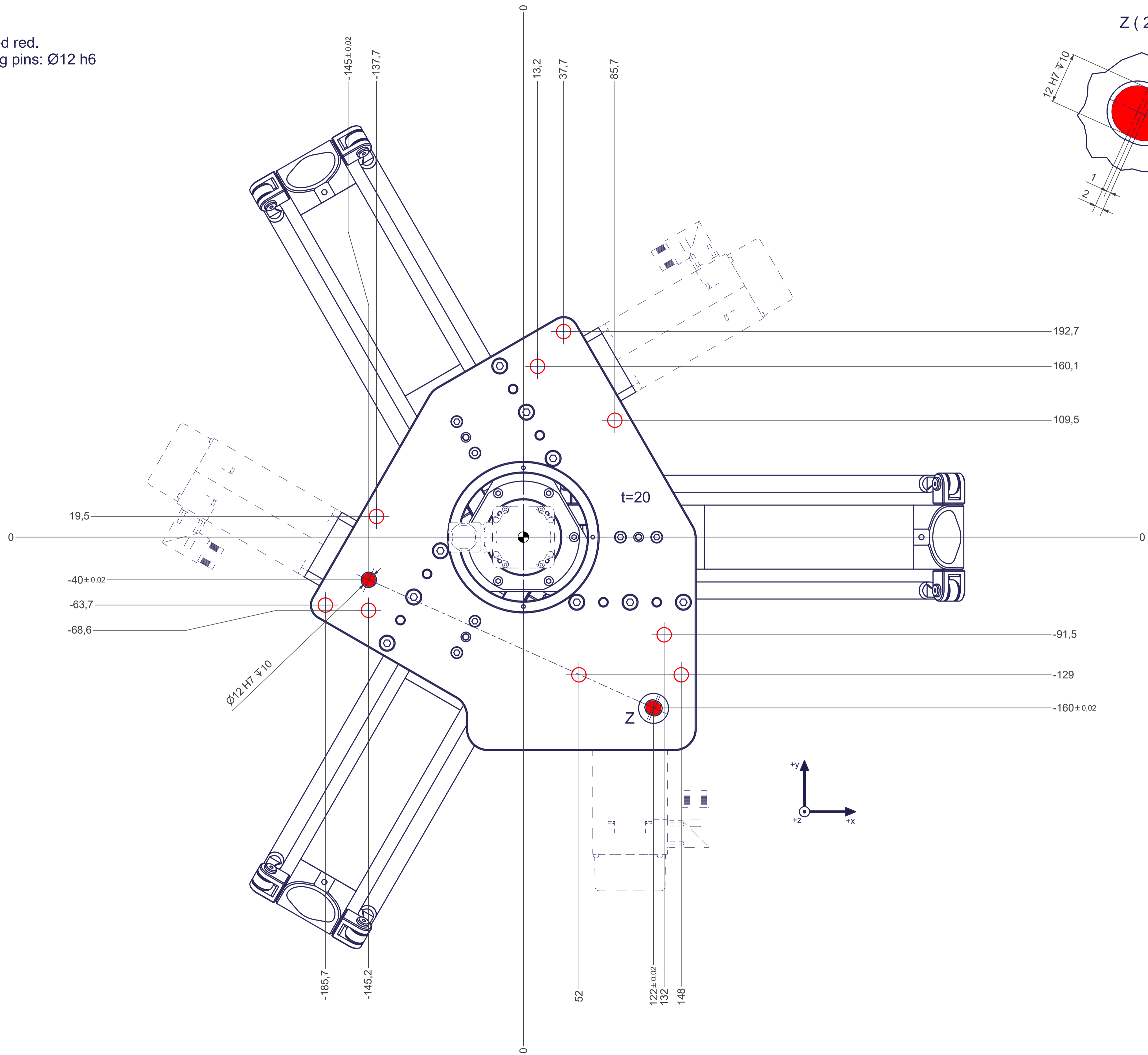

12 11 10 9 8 7 6 5 4 3 2 1