





12 11 10 9 8 7 6 5 4 3 2 1

-  All fastening holes  $\text{\O}22$  mm for screws M20 (DIN ISO 4014/4017 -8.8) without washers. Fastening holes are coloured red.
-  Drilling holes for locating pins are filled red. Recommended dimensions of locating pins:  $\text{\O}12$  h6
-  Thread holes for screws M20 are coloured green. The tightening torque for these screws (strength class 8.8) is 170 Nm.

Z (2:1)

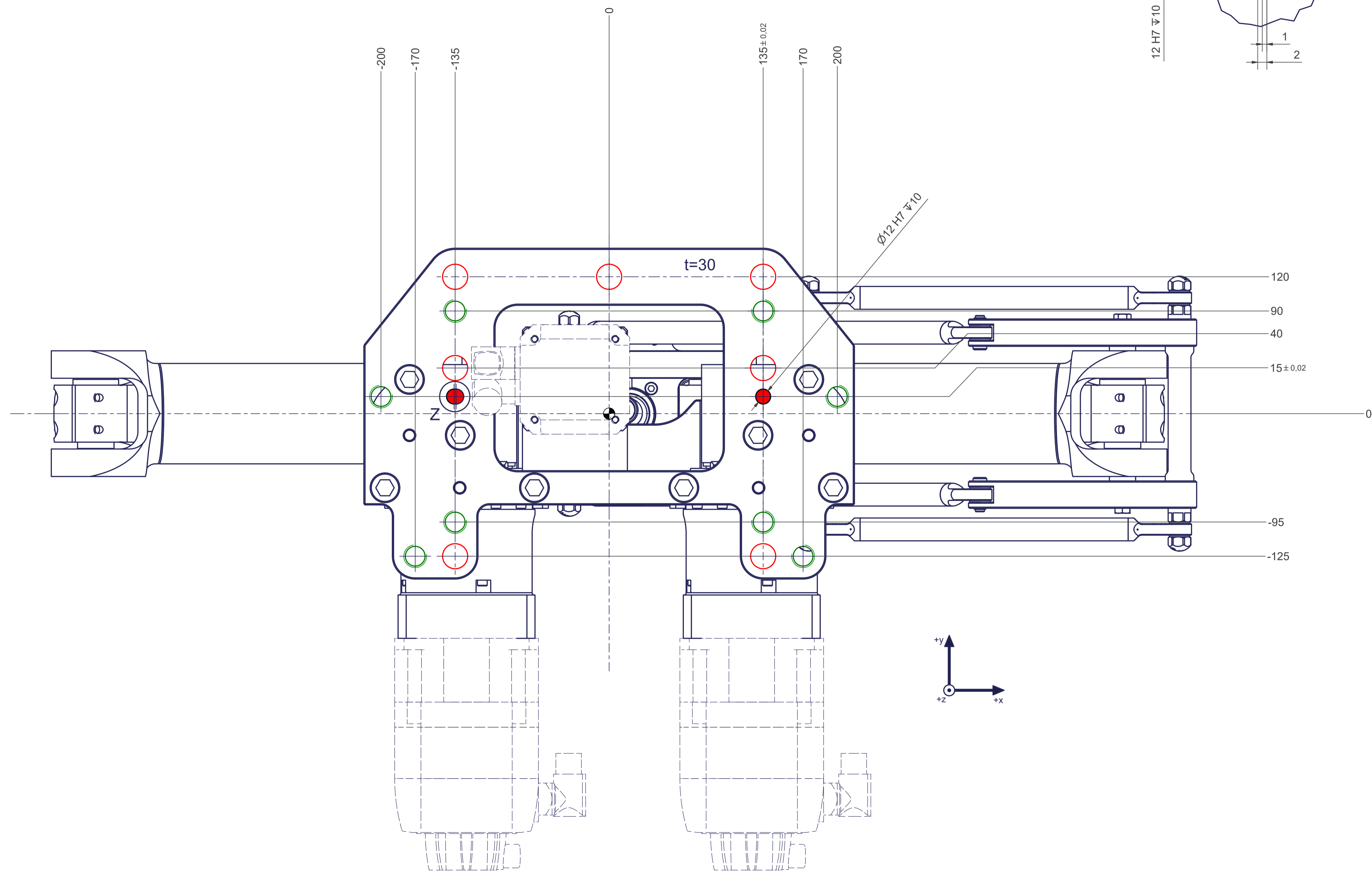
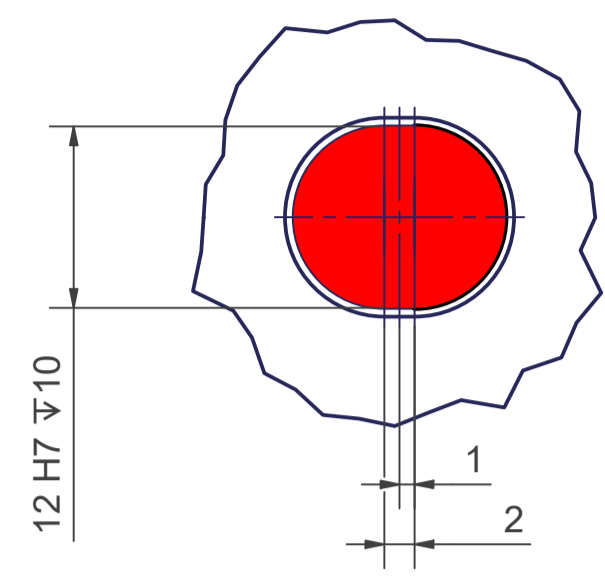

12 11 10 9 8 7 6 5 4 3 2 1