

Tool Center Point
TCP (on the plane of the flange)

TCP - working range

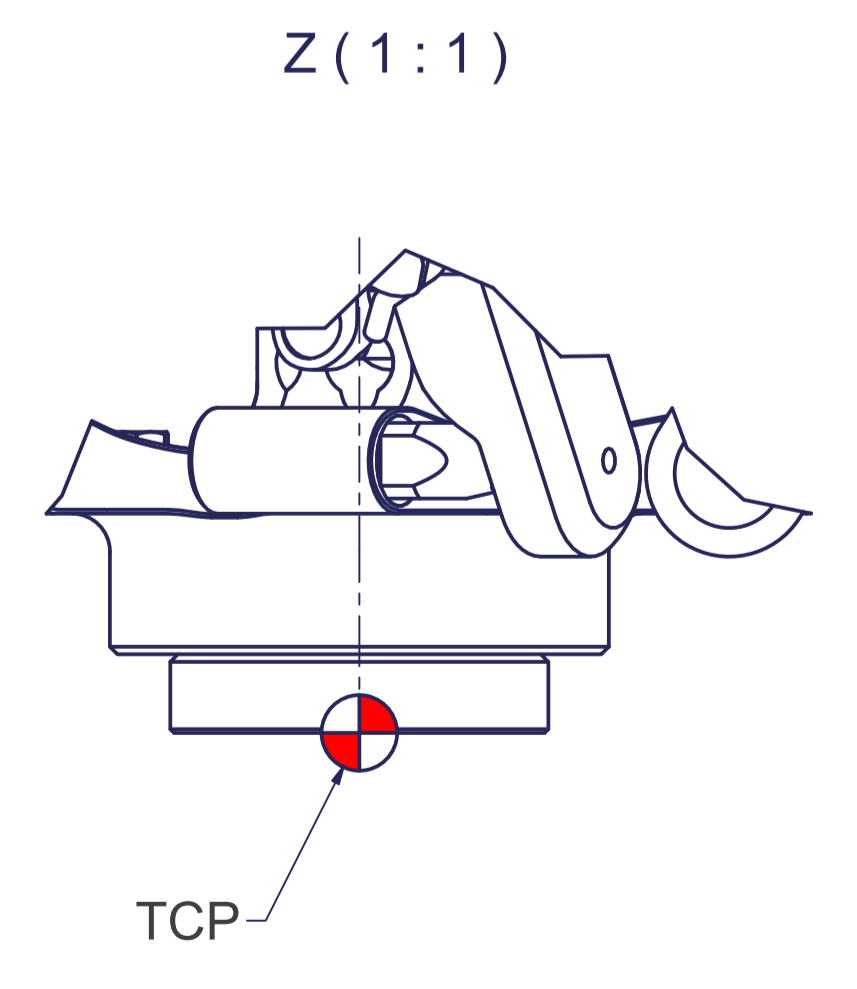
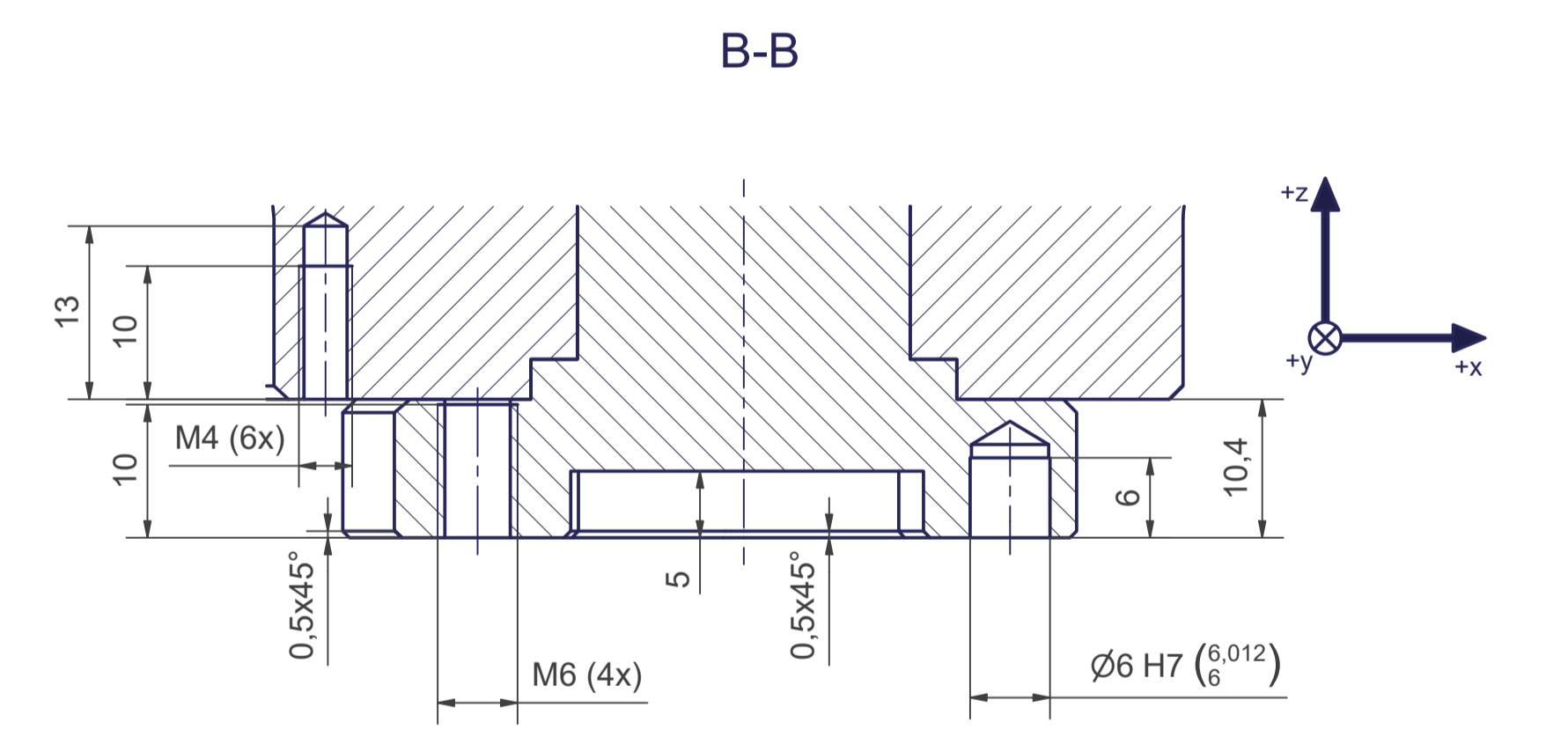
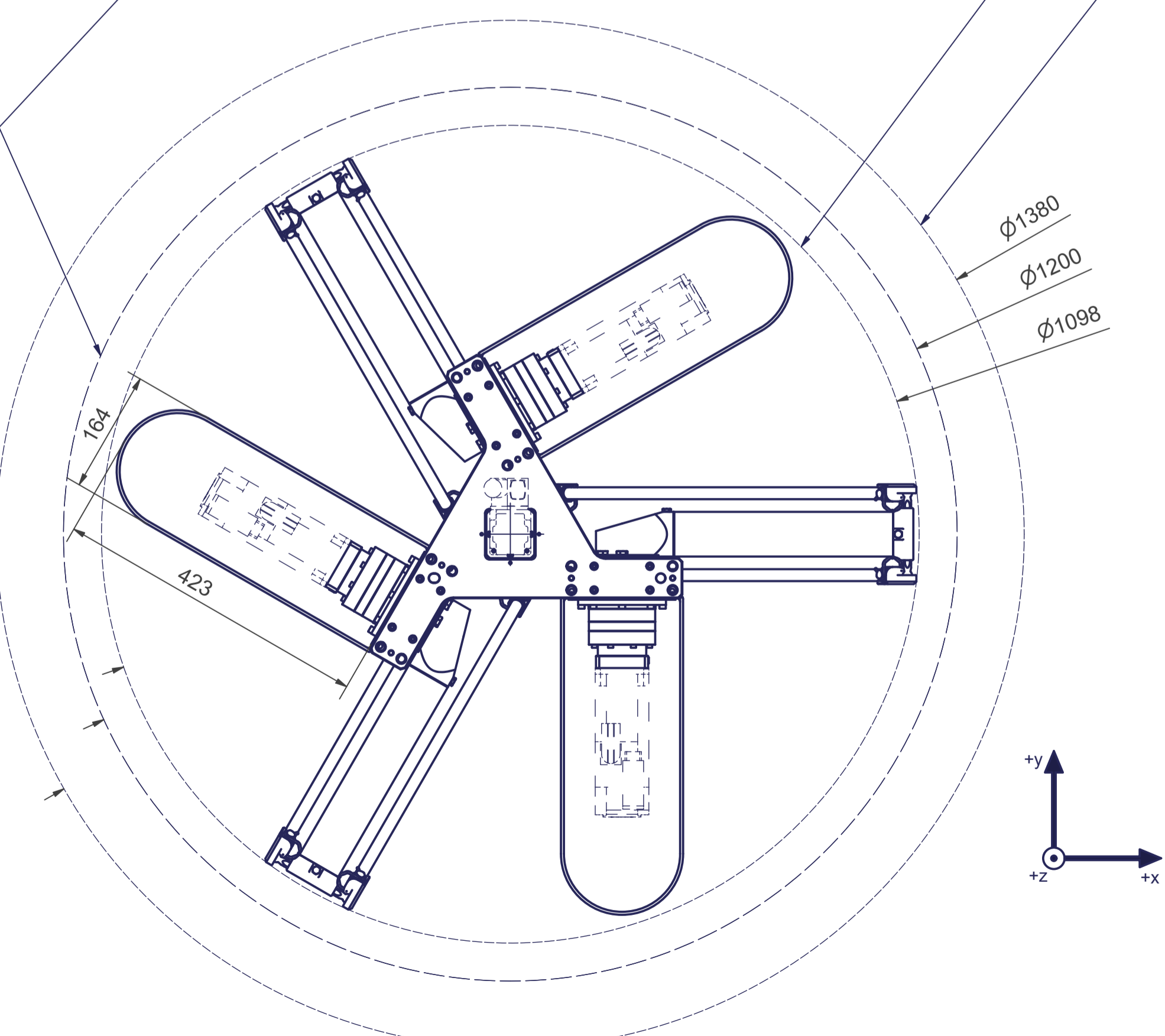

Connecting dimensions,
valid for article number AL_00006-HND

m= kg	A	p= bar
proj. storage surface = m²		∇ = l/min
First angle projection	P= kW	U= V / Hz / Ph
	U= V / Hz / Ph	
Imax= A	A	autonox lean line

12 11 10 9 8 7 6 5 4 3 2 1

○ Thread holes for screws M12 are coloured green.
The tightening torque for these screws (strength class 8.8) is 41 Nm.

● Drilling holes for location pins are filled red.
Recommended dimensions for locating pins: $\varnothing 12 \text{ h}8 \left(\begin{smallmatrix} 12 \\ 11,973 \end{smallmatrix} \right)$

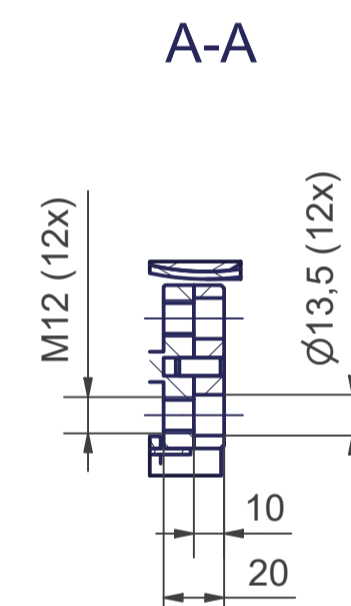
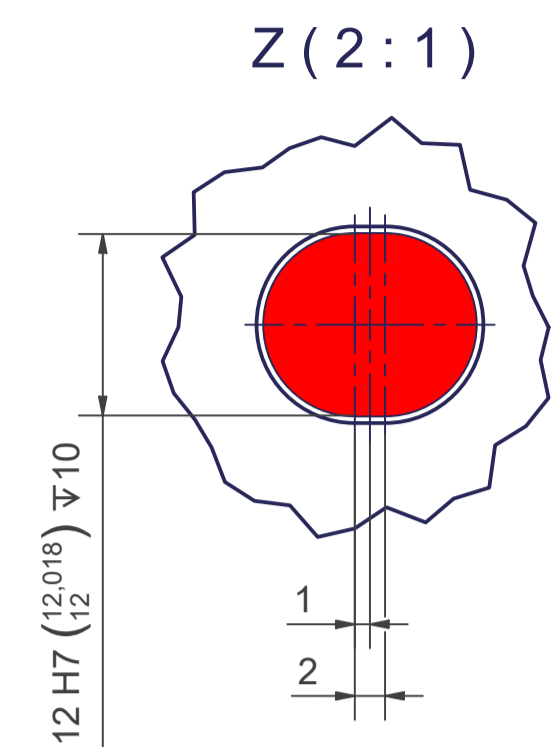
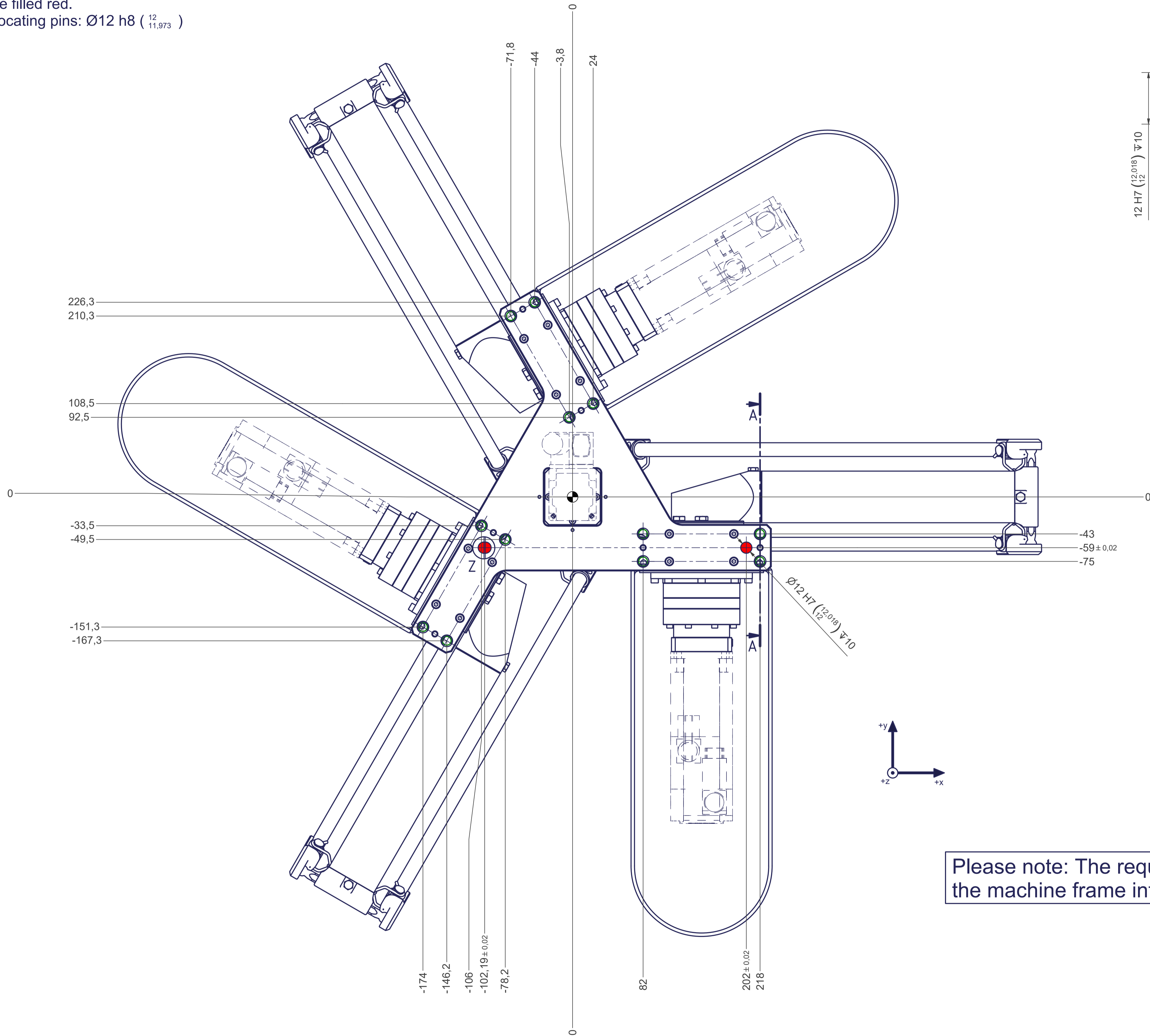

Please note: The required flatness of the machine frame interface is 0,1mm.

12 11 10 9 8 7 6 5 4 3 2 1