

Interference contour from machine body

Maximum interference contour

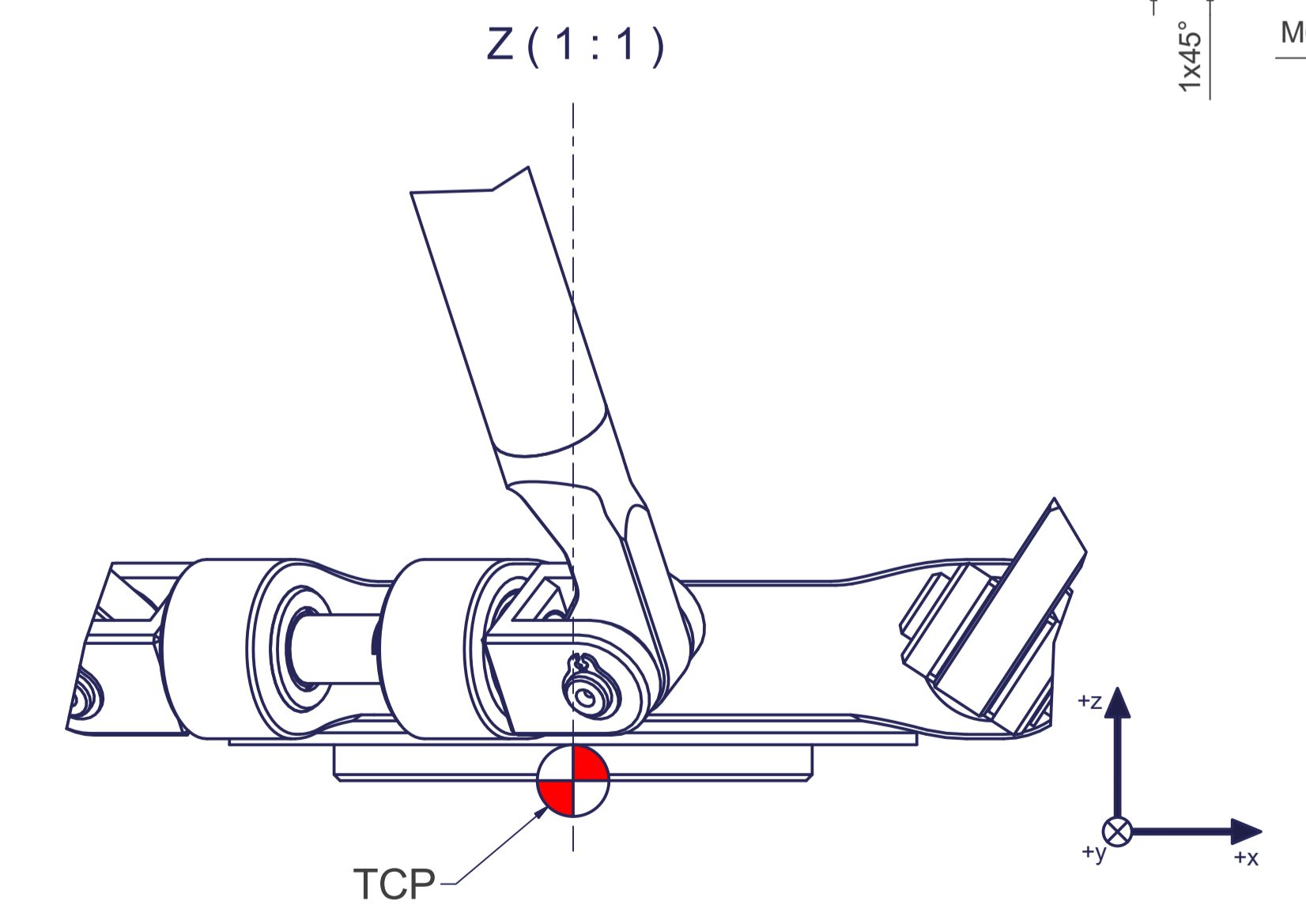
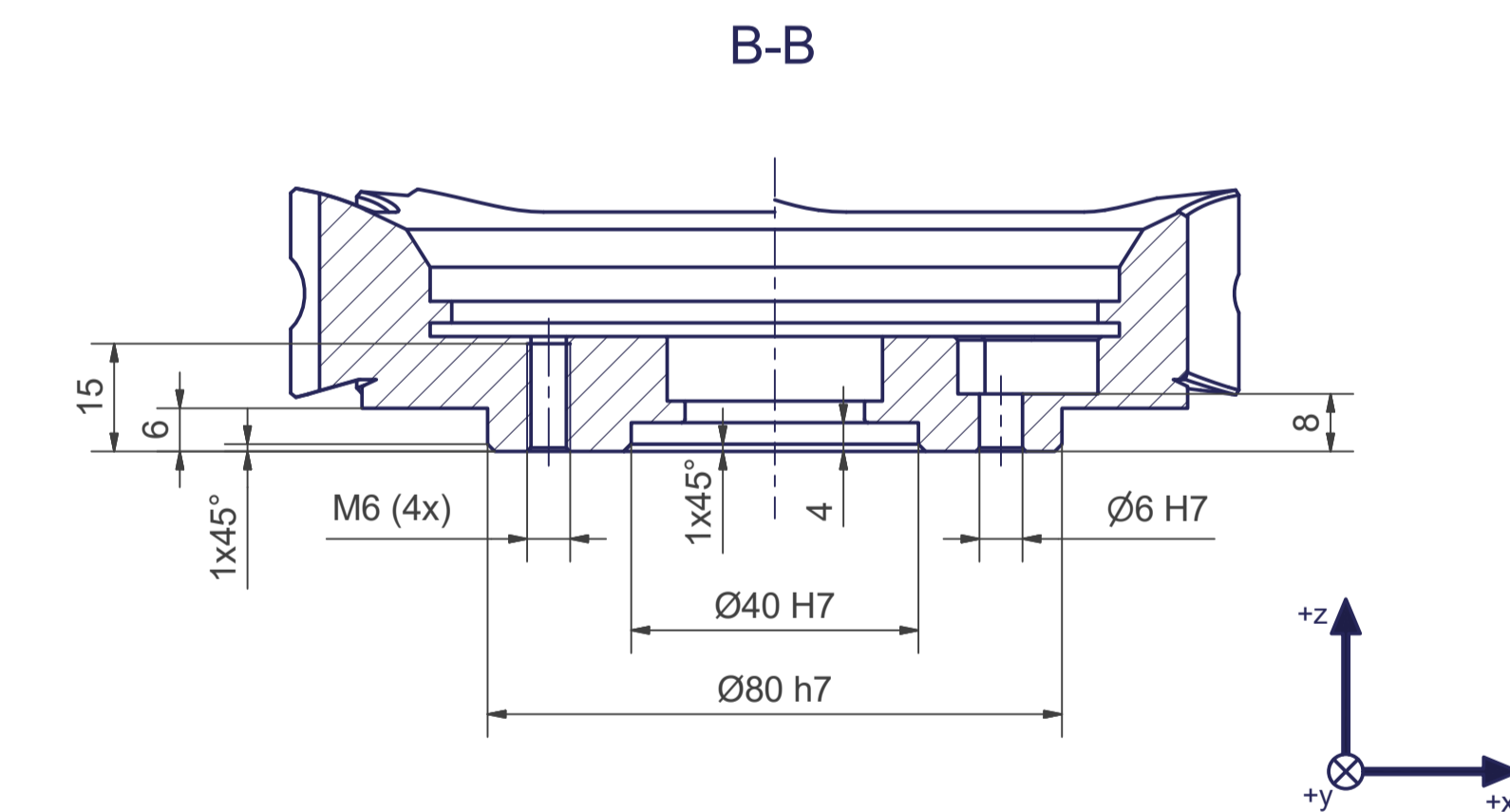

Connecting dimensions, valid for article number A\_00863

m= kg	A	p= bar
proj. storage surface = m²		v̇= l/min
First angle projection	P= kW	U= V / Hz / Ph
	U=	I <sub>max</sub> = A



12

11

10

9

8

7

6

5

4

3

2

1

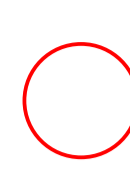

All fastening holes  $\varnothing 17,5$  mm for screws M16 (DIN ISO 4014/4017 -8.8) without washers. Fastening holes are coloured red.

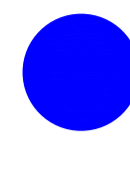

Fastening holes filled blue are difficult to access. We recommend using fastening holes coloured red.



Drilling holes for locating pins are filled red. Recommend dimensions of locating pins:  $\varnothing 12$  h6

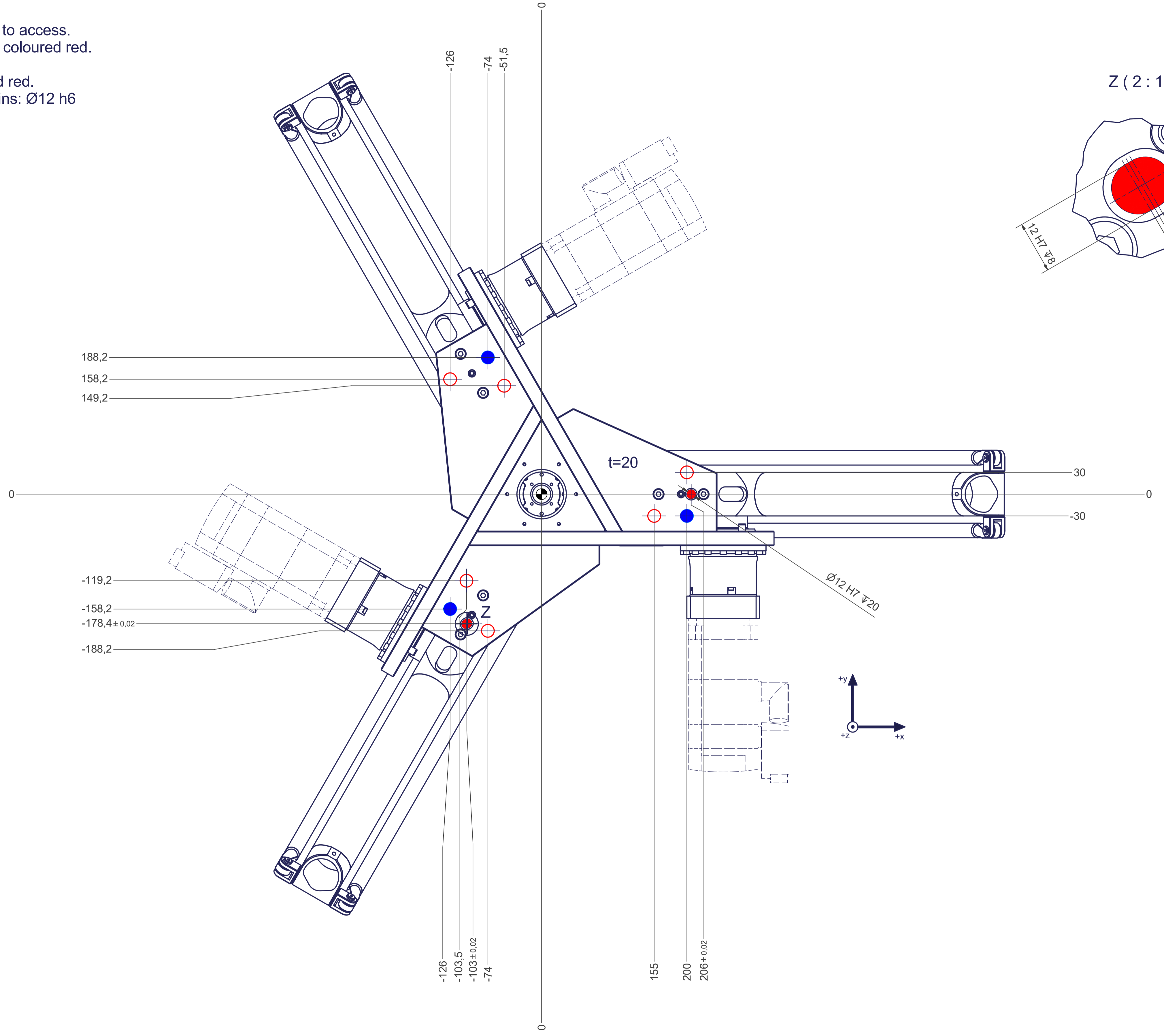

12

11

10

9

8

7

6

5

4

3

2

1