

12 11 10 9 8 7 6 5 4 3 2 1

- All fastening holes $\varnothing 17,5\text{mm}$ for screws M16 (DIN ISO 4014/4017 -8.8) without washer. Fastening holes are coloured red.
- Fastening holes filled blue are difficult to access. We recommend using fastening holes coloured red.
- Drilling holes for locating pins are filled red.

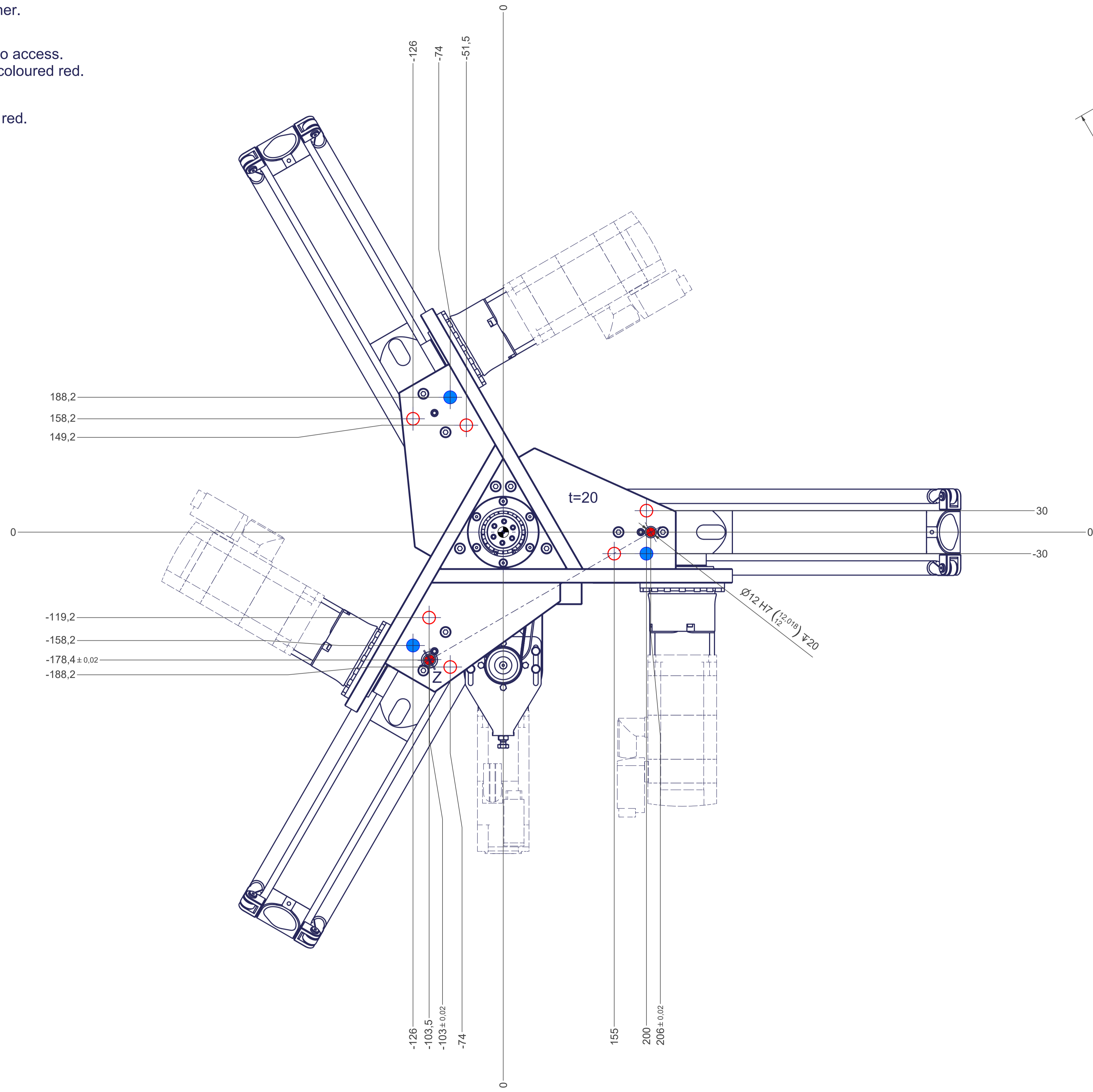
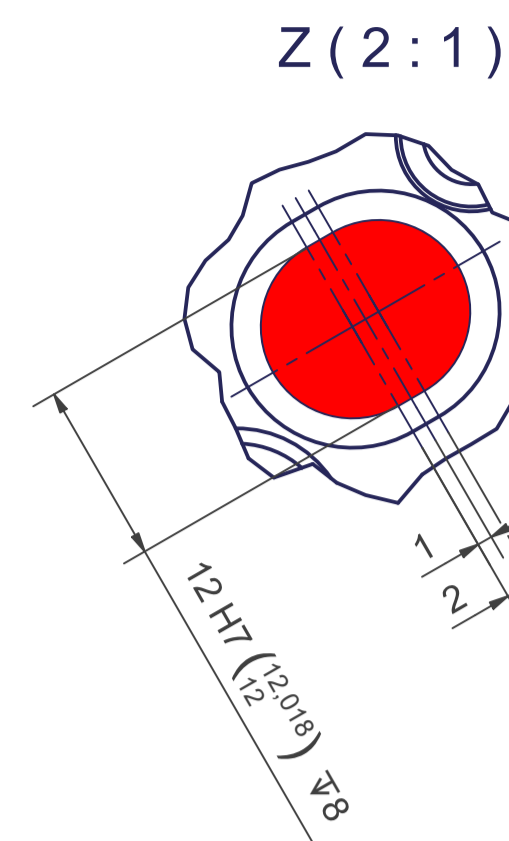

12 11 10 9 8 7 6 5 4 3 2 1