

Connecting dimensions, valid for article number A_00909-T1

m= kg	A	p= bar
proj. storage surface = m²	P= kW	v= l/min
First angle projection	U= V / Hz / Ph	
	Imax= A	

12 11 10 9 8 7 6 5 4 3 2 1

- All fastening holes $\varnothing 22$ for screws M20 (DIN ISO 4014/4017 -8.8) without washer. Fastening holes are coloured red.
- Drilling holes for locating pins are filled red. Recommended dimensions of locating pins: $\varnothing 12$ h6.
- Thread holes for screws M20 are coloured green. The tightening torque for these screws (strenght class 8.8) is 170 Nm.

Z (2:1)

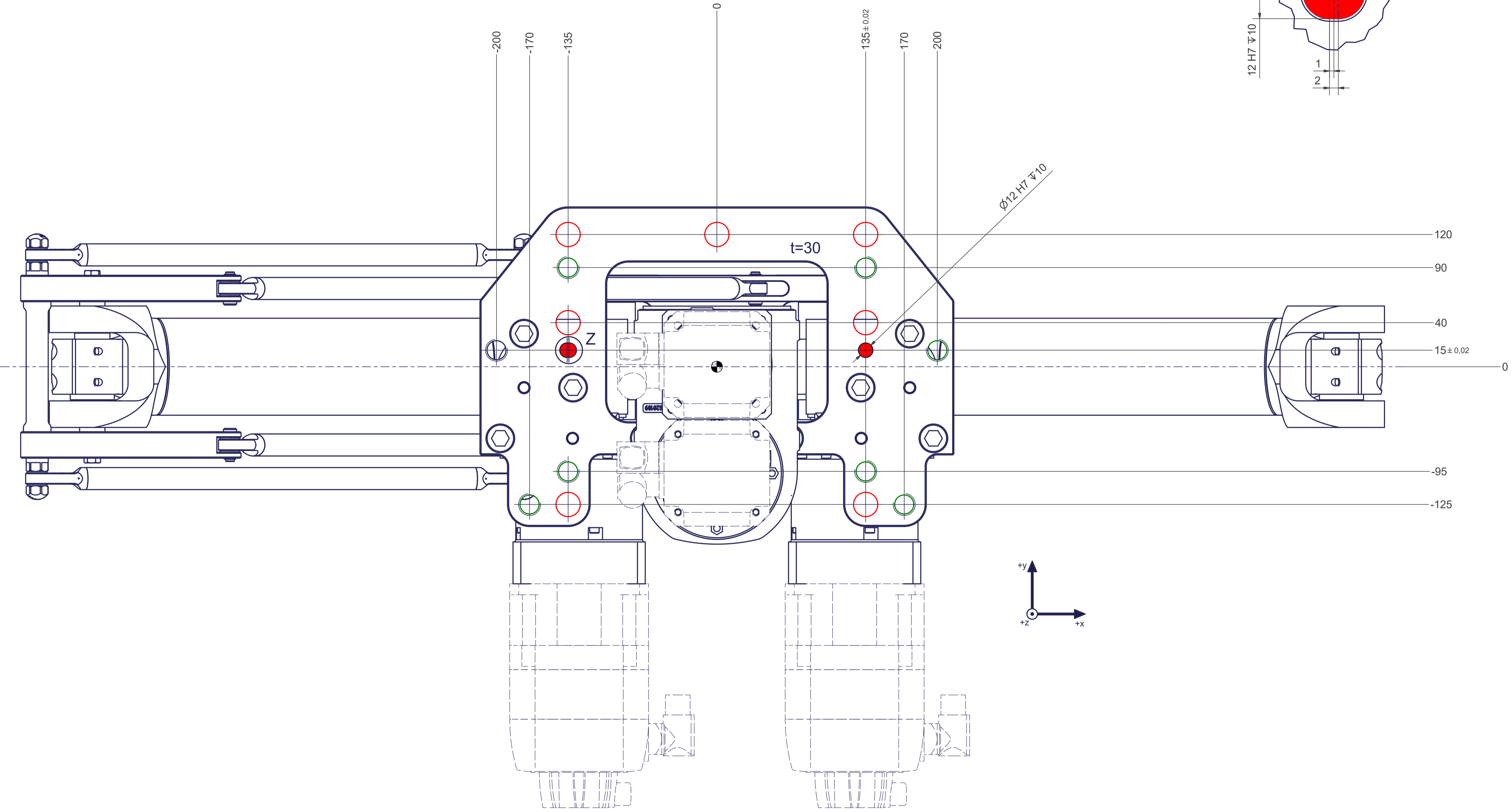
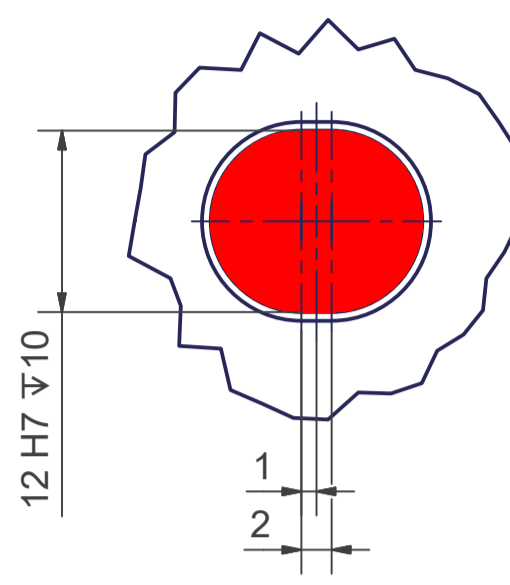

12 11 10 9 8 7 6 5 4 3 2 1