



Connecting dimensions, valid for article number A_00896

m= kg	A	p= bar
proj. storage surface = m²	P= kW	\dot{V} = l/min
First angle projection	U= V / Hz / Ph	
	Imax= A	

12 11 10 9 8 7 6 5 4 3 2 1

-  All fastening holes $\varnothing 13,5$ mm for screws M12 (DIN ISO 4014/4017 -8.8) without washers. Fastening holes are coloured red.
-  Drilling holes for locating pins are filled red. Recommended dimensions of locating pins: $\varnothing 12$ h6 mm

Z (2:1)

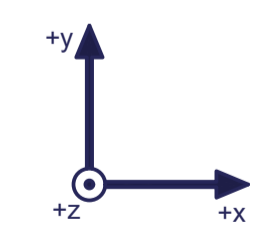
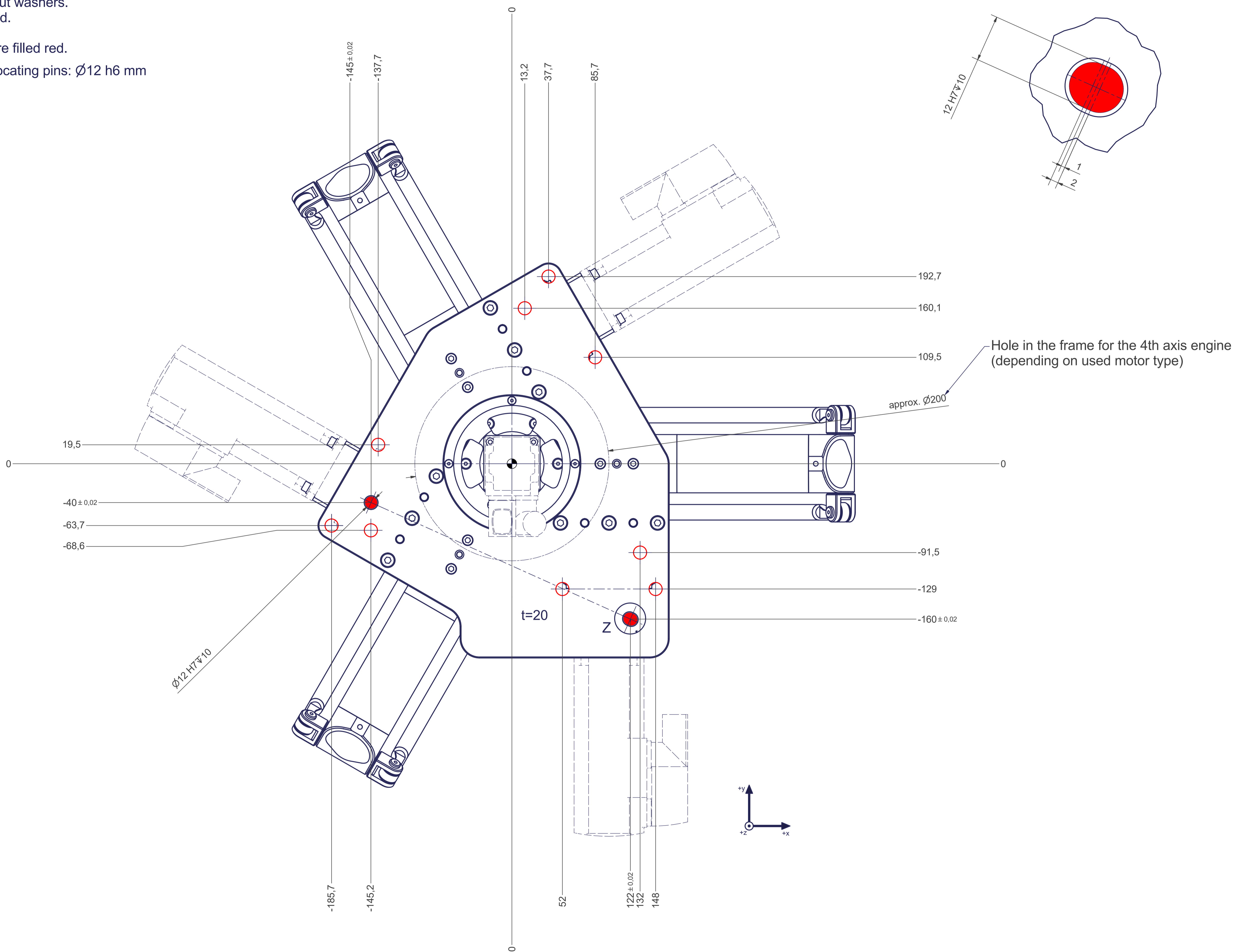
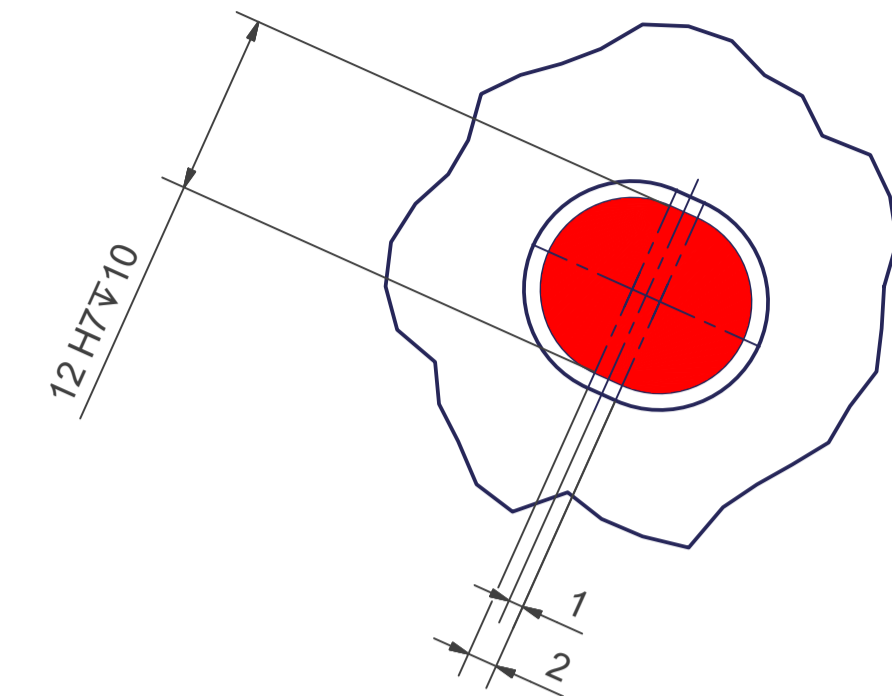

12 11 10 9 8 7 6 5 4 3 2 1