

Optional Bellows (1:2)

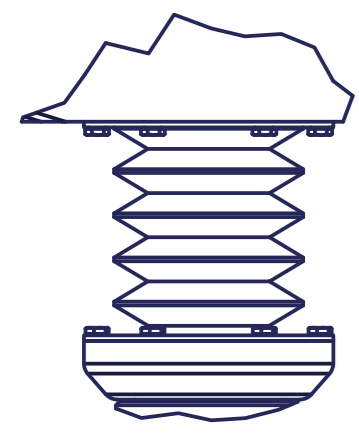

TCP - working range when using optional Bellows (MT_BGR00104375)

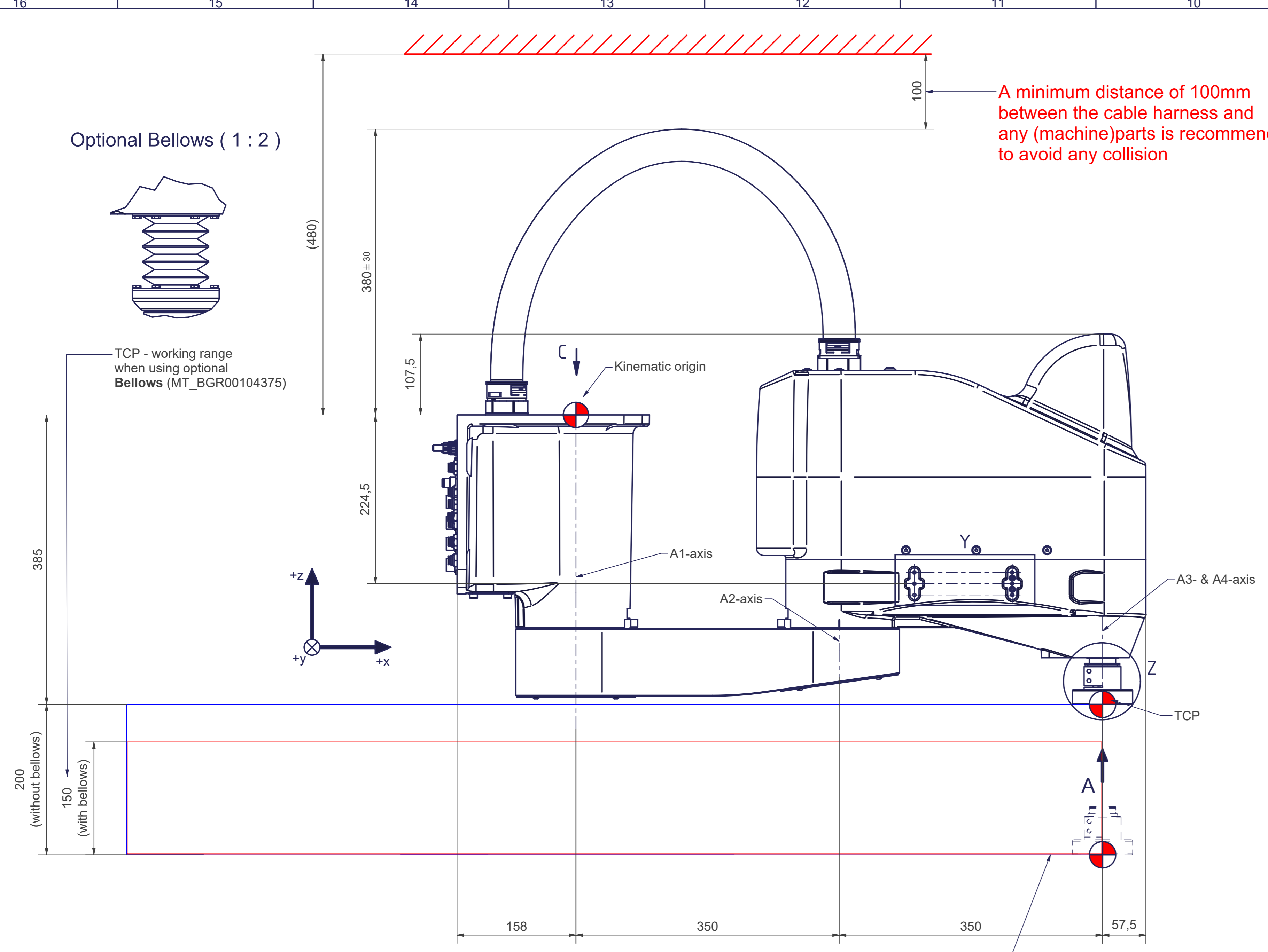

A minimum distance of 100mm between the cable harness and any (machine)parts is recommended to avoid any collision

A (2:1)
Tool mounting flange

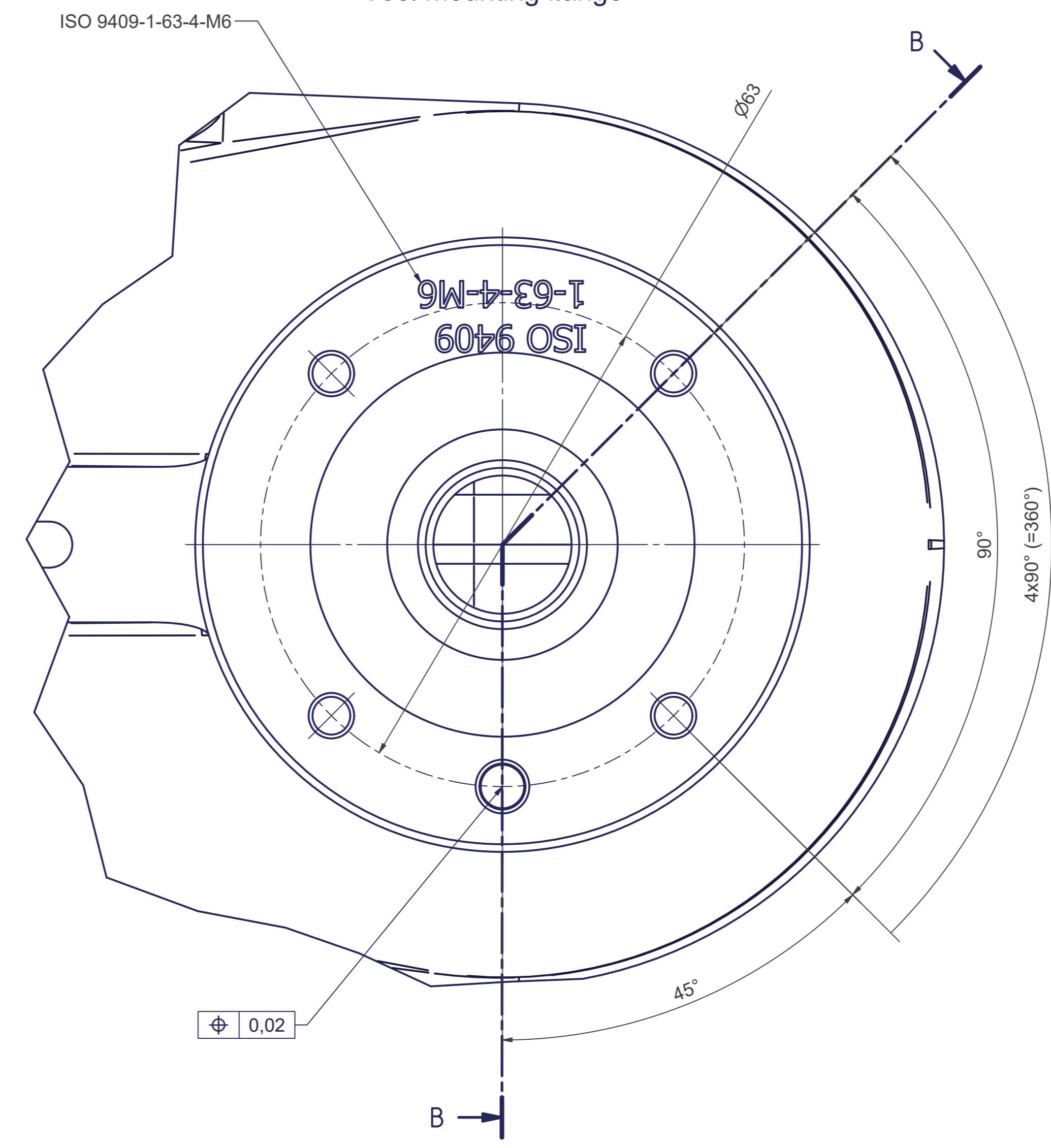

B-B

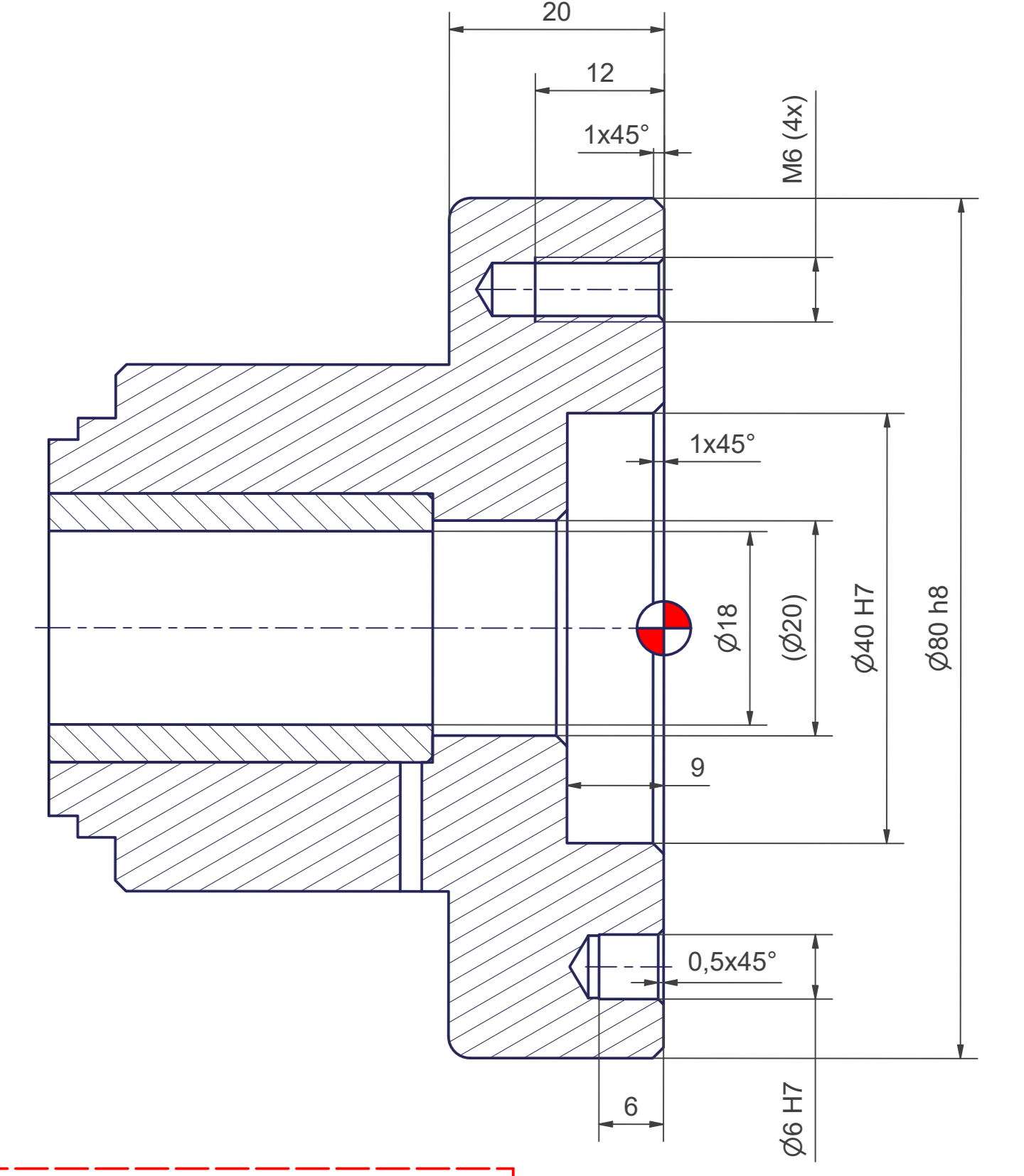

PIN assignment by autonox Robotics

PIN number	Connection to	M12 8-pin male
1	Push button	
2	Push button	
3 to 8	Not connected	

Y (1:2)

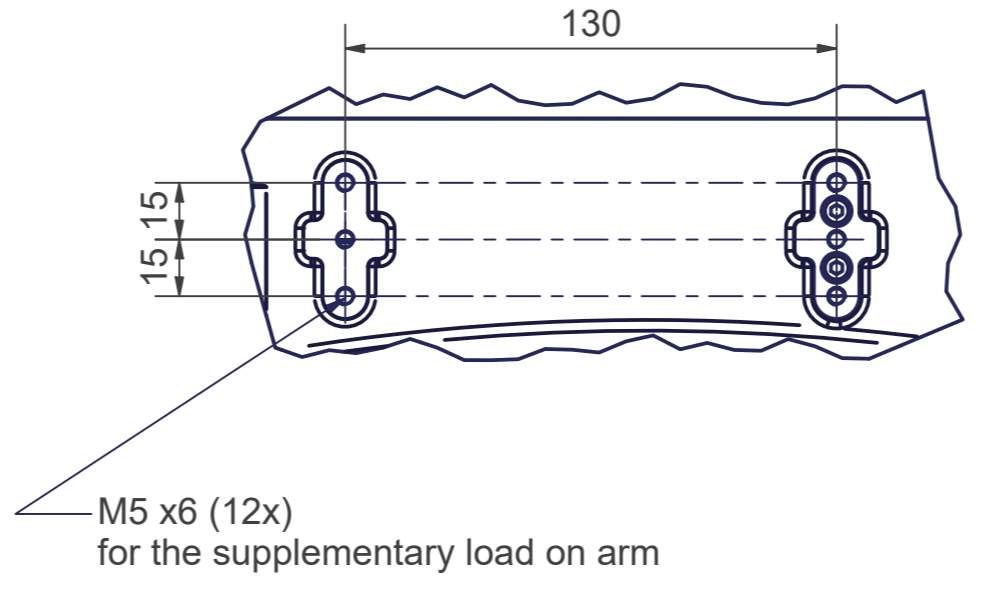

C (1:2)
Base frame

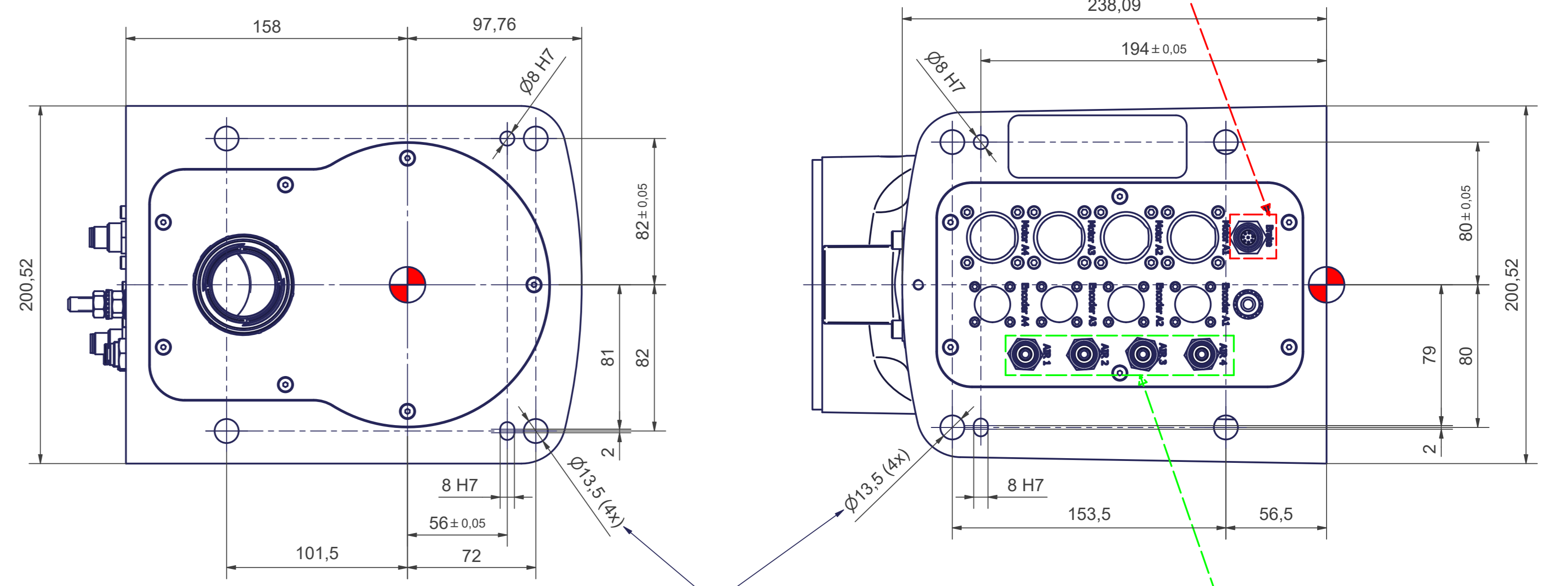

for screws M12 (DIN ISO 4014/4017-8.8) the tightening torque for these screws is 83 Nm (in steel frame).

Incl. fourfold integrated media supply to the end effector (compressed air 8 bar / vacuum -1 bar / D = 6mm d = 4mm)

Push button, for example to be able to release the motor brakes (details for connection see table "PIN assignment")

Maximum interference

Z (1:1)

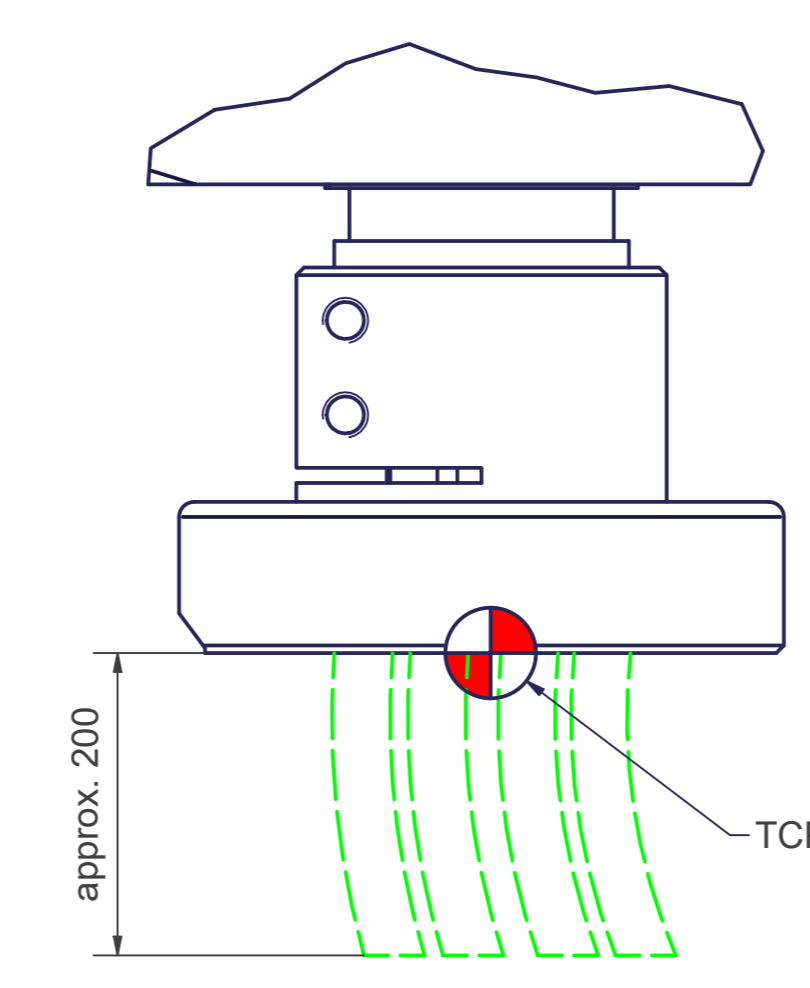

Incl. fourfold integrated media supply to the end effector (compressed air 8 bar / vacuum -1 bar / D = 6mm d = 4mm)

X (1:2)

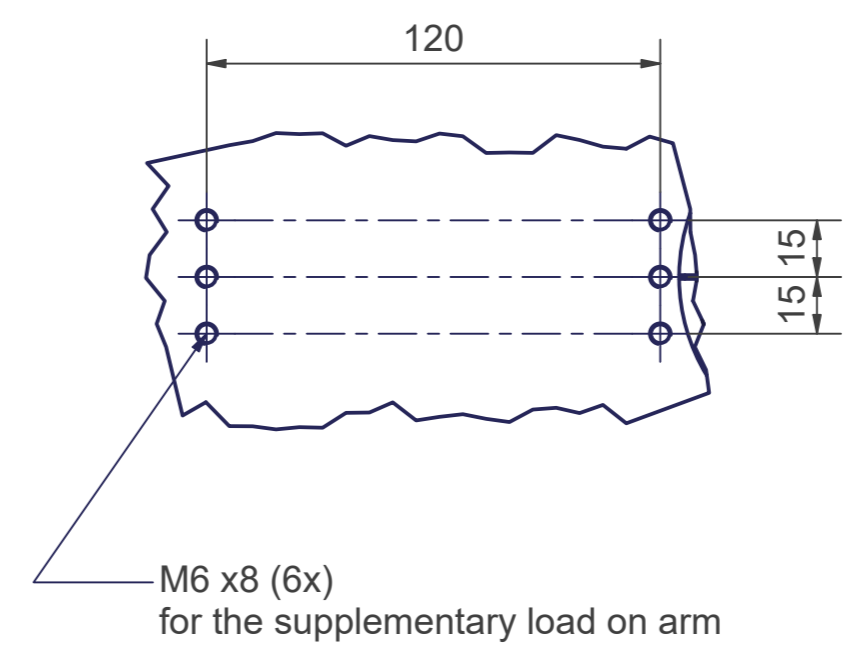

sCara4-700-6kg		Motion	
Axes	4	Axes	Range fully usable
Payload (on TCP)	6 kg	A1	± 135°
Reach	700 mm	A2	± 145°
Mounting position	Floor, ceiling, wall	A3	- 385 mm / - 585 mm
		A4	± 360°

More information can be found in the document "calibration dimensions"

Connecting dimensions, valid for article number: AT_00020-01

kg	kg	A	bar
m ⁻	m ²	P _z	l/min
proj. storage surface =		U _n	V / Hz / Ph
		l _{max}	

OPTIONAL:

Bellows MT_BGR00104375

