

12

11

10

9

8

7

6

5

4

3

2

1

○ All fastening holes $\varnothing 17,5$ mm for screws M16 (DIN ISO 4014/4017 -8.8) without washers. Fastening holes are coloured red.

● Drilling holes for locating pins are filled red. Recommended dimensions of locating pins: $\varnothing 12$ h6 ($\begin{smallmatrix} 12 \\ 11,989 \end{smallmatrix}$)

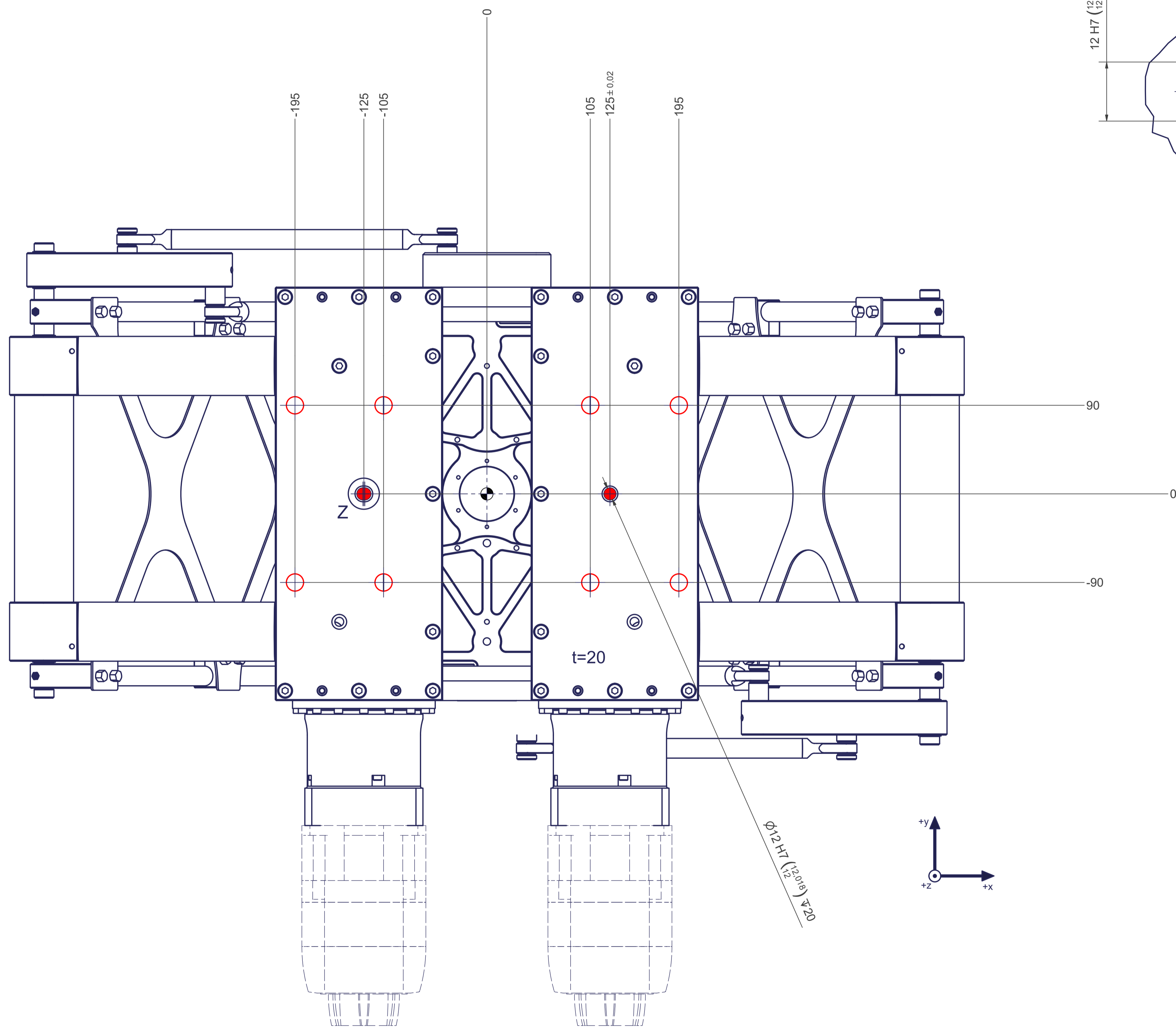
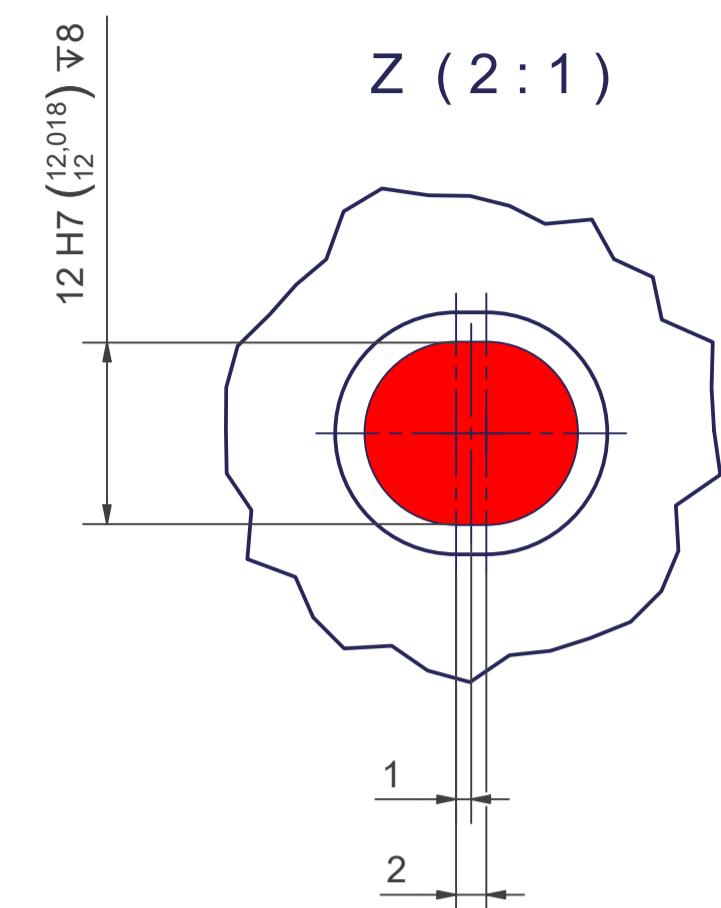

12

11

10

9

8

7

6

5

4

3

2

1