



m= kg	A	p= bar
projected storage surface = m²	P= kW	v= l/min
	U= V / Hz / Ph	
	I <sub>max</sub> = A	

12 11 10 9 8 7 6 5 4 3 2 1

-  All fastening holes  $\varnothing 22$  for screws M20 (DIN ISO 4014/4017 -8.8) without washer. Fastening holes are coloured red. The tightening torque for these screws (strength class 8.8) is 360 Nm (in a steel frame).
-  Drilling holes for locating pins are filled red. Recommended dimensions of locating pins:  $\varnothing 12$  h6
-  Thread holes for screws M20 are coloured green. The tightening torque for these screws (strength class 8.8) is 170 Nm.

Z (2:1)

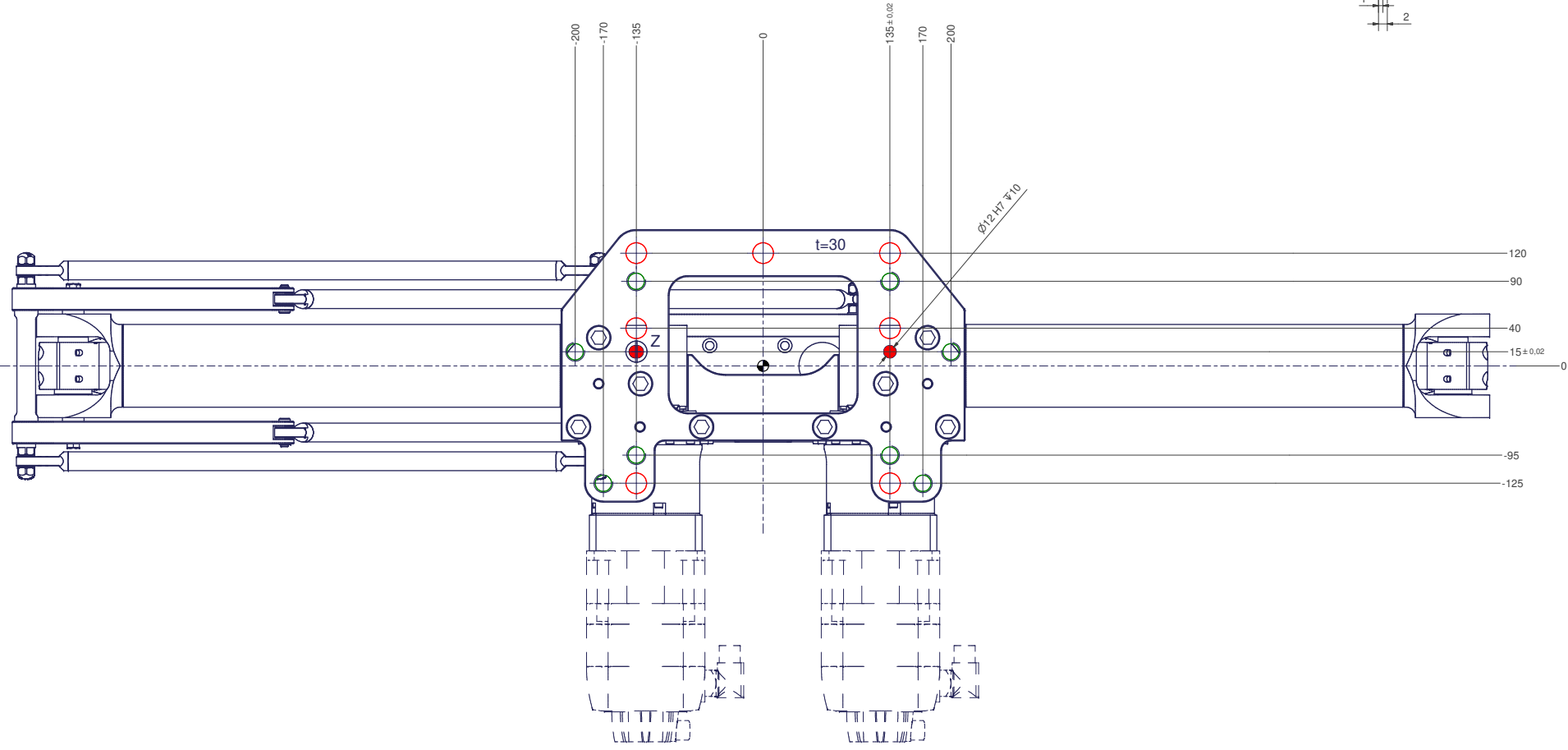
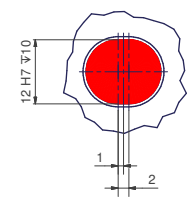

12 11 10 9 8 7 6 5 4 3 2 1