

Motion	
Axes	Range fully usable
A1	± 185°
A2	-90° / +120° (*)
A3	-183° / +66° (*)
A4	± 360°
A5	± 120°
A6	± 360°

More information can be found in the document "calibration dimensions"
 (*) only if the axis 1 motor doesn't exceed a length of 250 mm, otherwise these values must be reduced to avoid any risk of collision

articc6-2757-20kg	
Axes	6
Payload (on TCP)	20 kg
Supplementary load on arm	40 kg
Supplementary load on rotating column	70 kg
Reach	2757 mm
Mounting position	Floor, ceiling

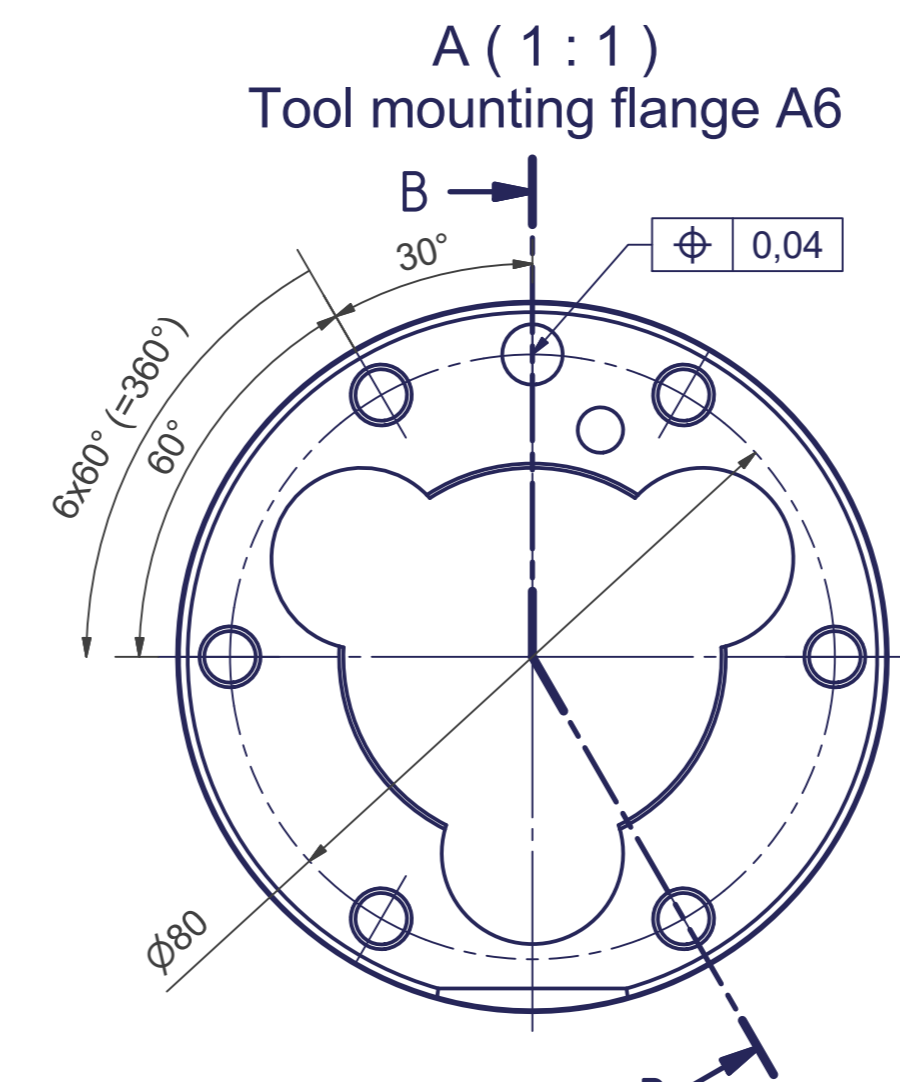
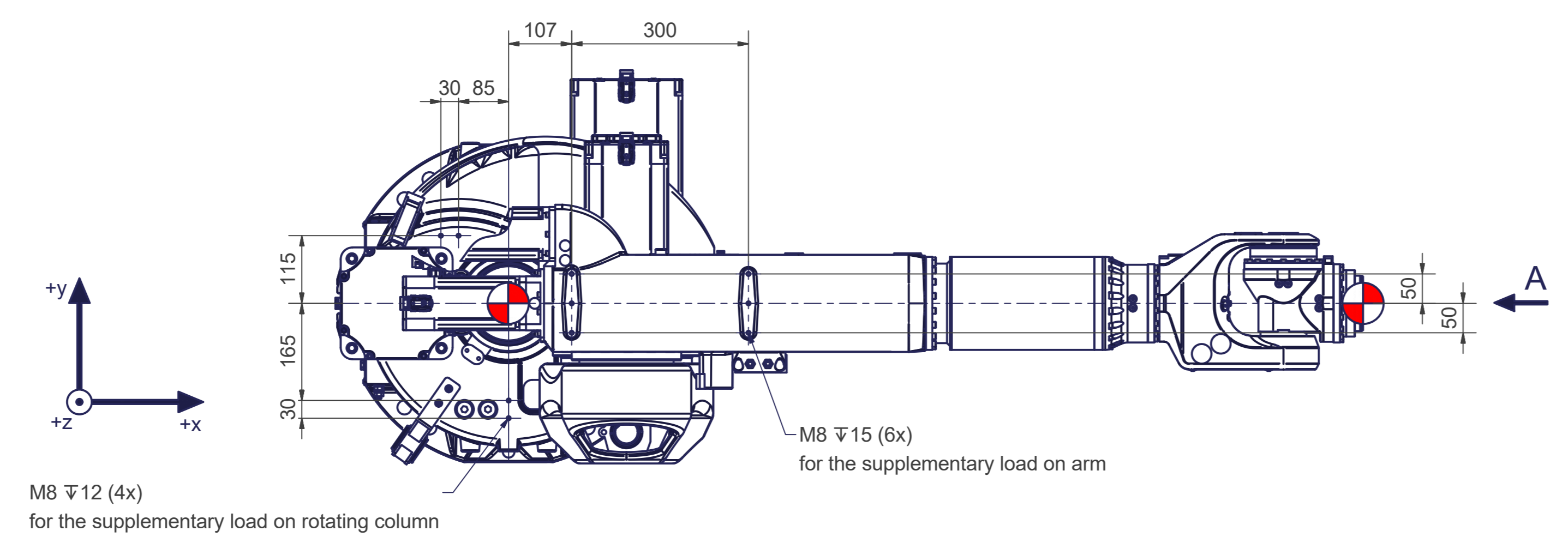

Connecting dimensions, valid for article number: AT_00028

Für diese Zeichnung behalten wir uns alle Rechte vor. Ohne unsere vorherige Zustimmung darf sie weder ververvielfältigt noch Dritten zugänglich gemacht werden, und sie darf durch den Empfänger oder Dritte auch nicht in anderer Weise missbräuchlich verwendet werden.	Allgemein-toleranz ISO 2768 m	Werkstück-karten ISO 13715	Maßstab 1 : 7
	Datum: 24.05.2022 Name: [unreadable] Zeichner: [unreadable]		articc6-2757-20kg
			AT_00028
			2 / A0