

Tool Center Point
TCP (on the plane of the flange)

TCP - working range

Depending on the motor type

Interference contour from machine body
Maximum interference contour

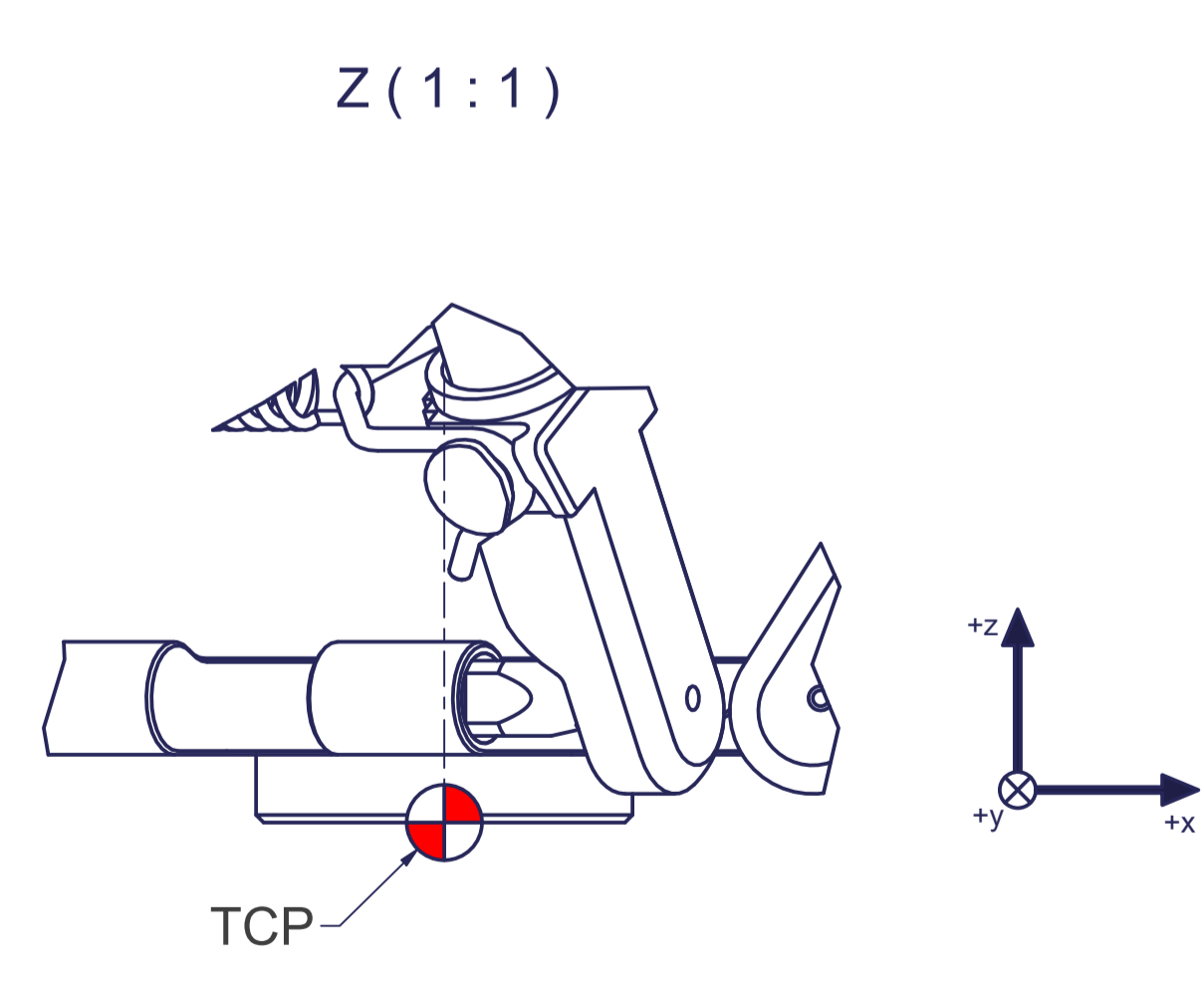
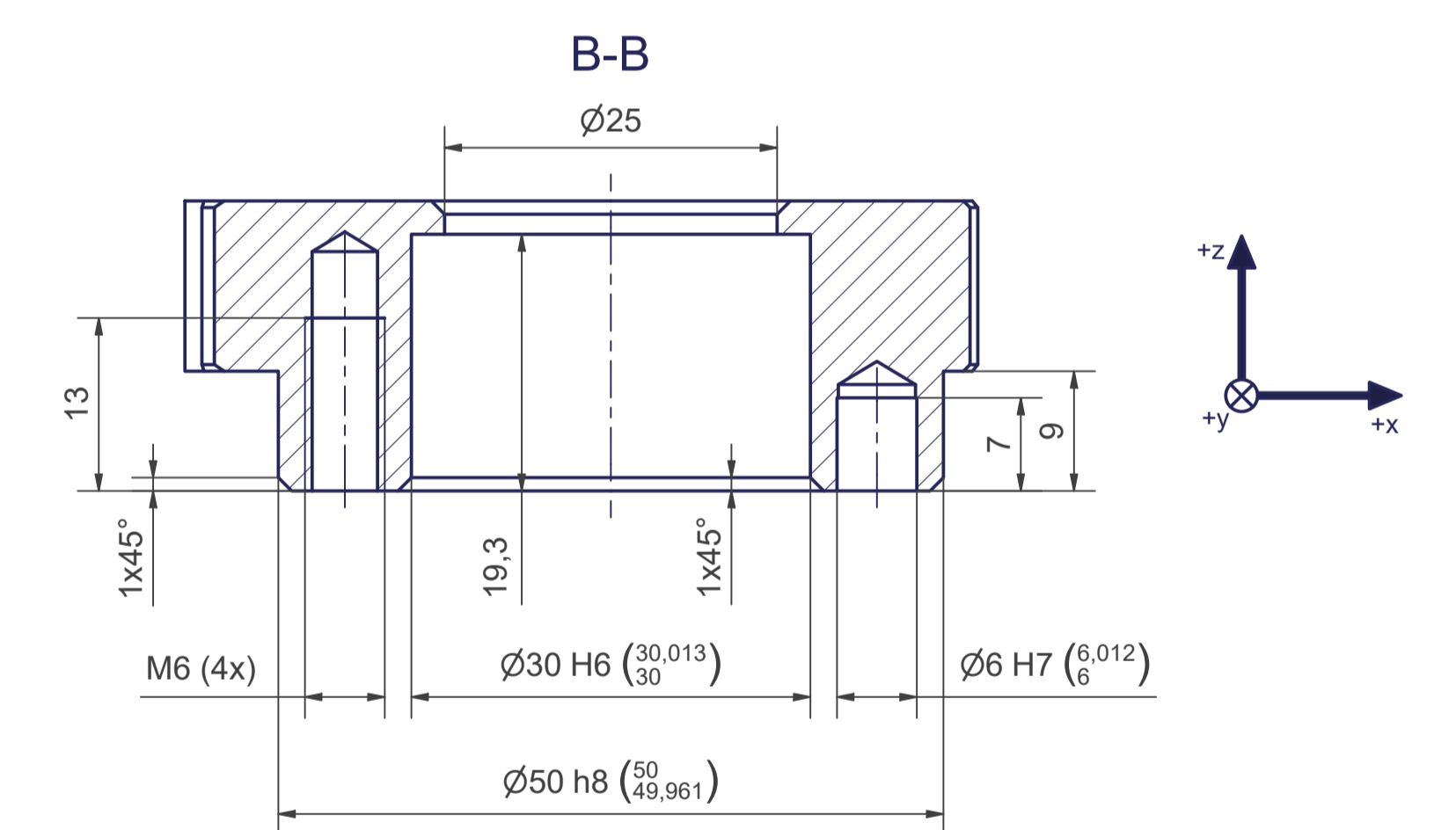
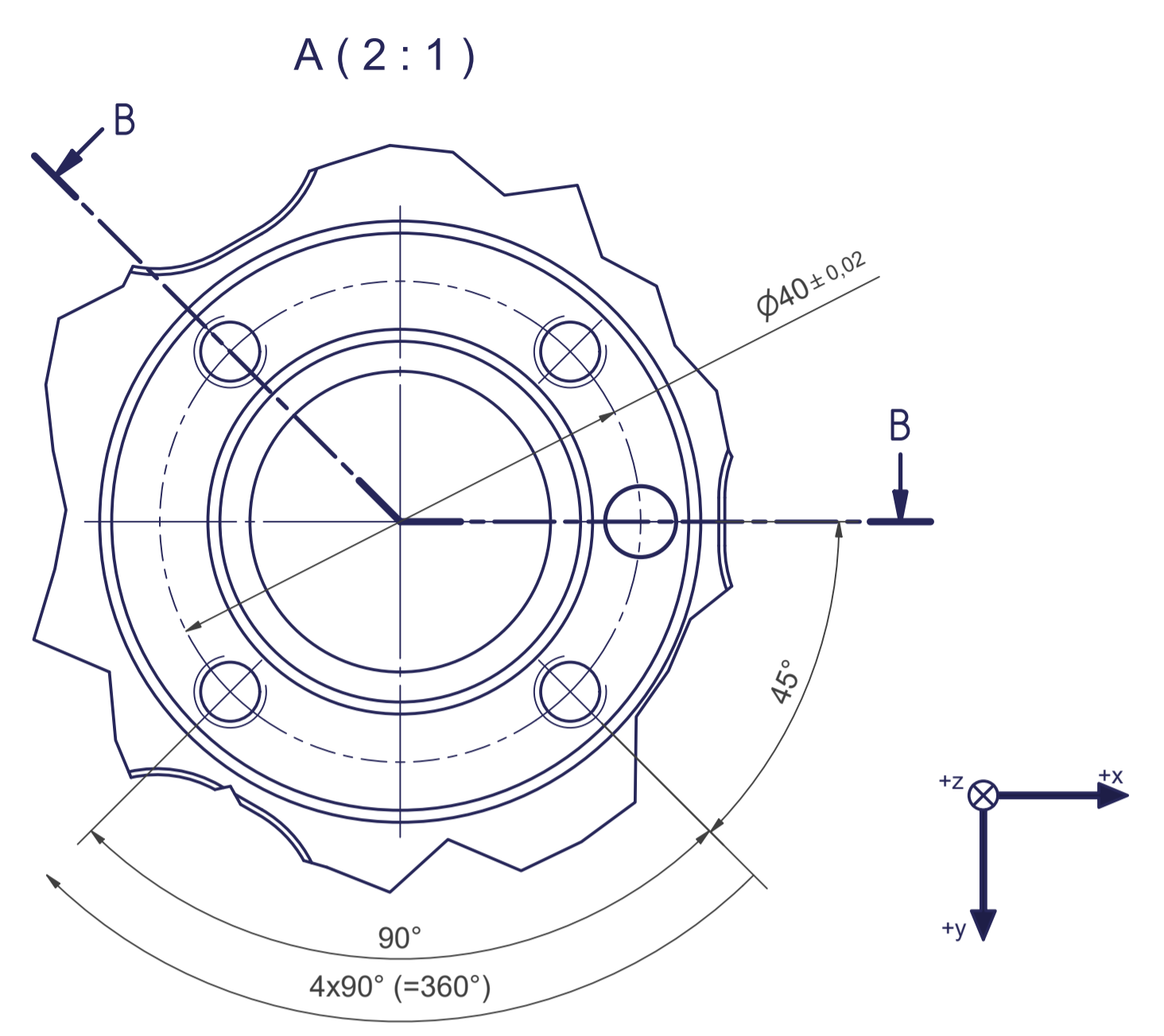
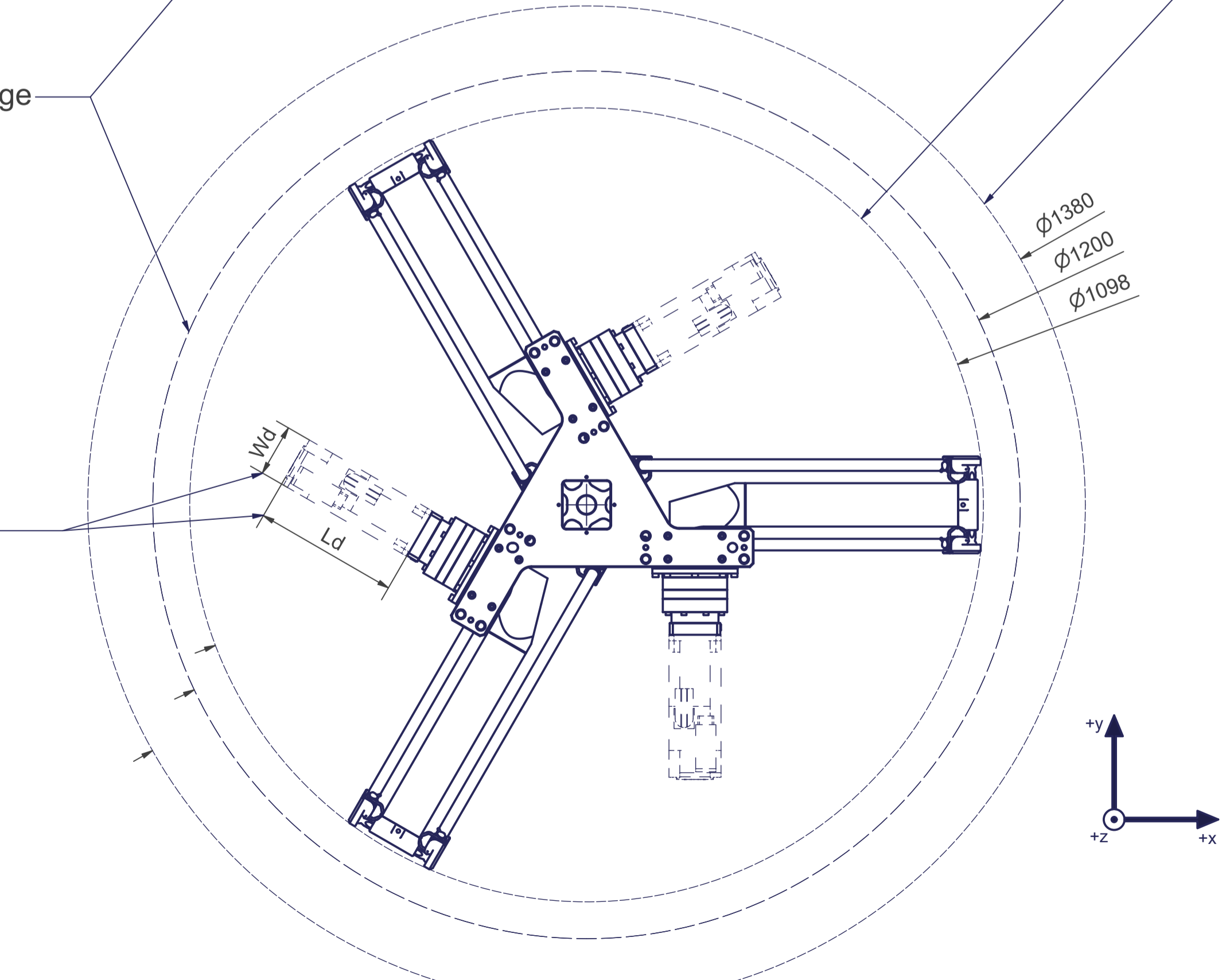

m= kg	A	p= bar
proj. storage surface = m²		v̇= l/min
First angle projection		P= kW
		U= V / Hz / Ph
		I _{max} = A
		autonox lean line

