

Tool Center Point
TCP (on the plane of the flange)

TCP - working range

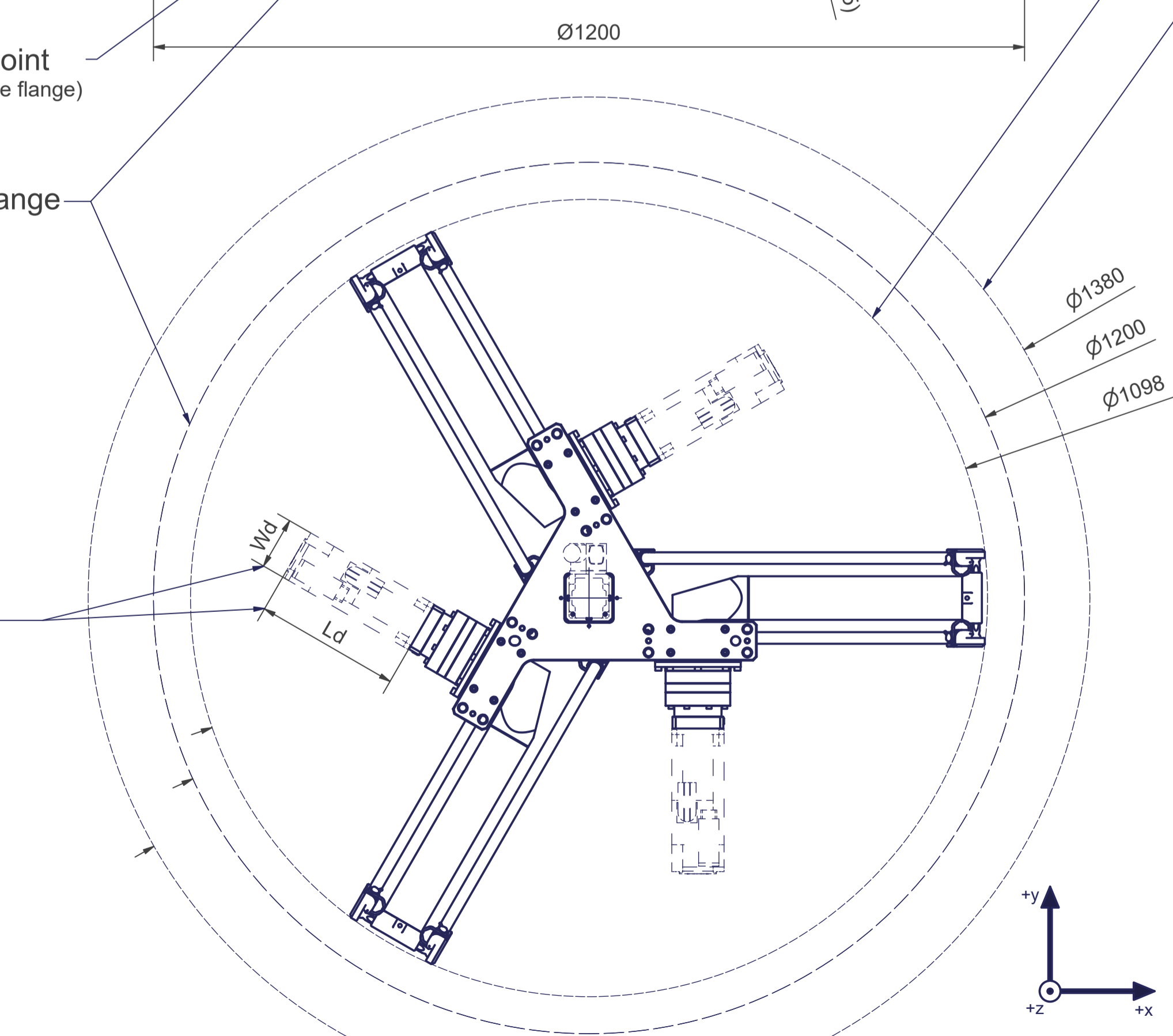

Interference contour
from machine body

Maximum interference
contour

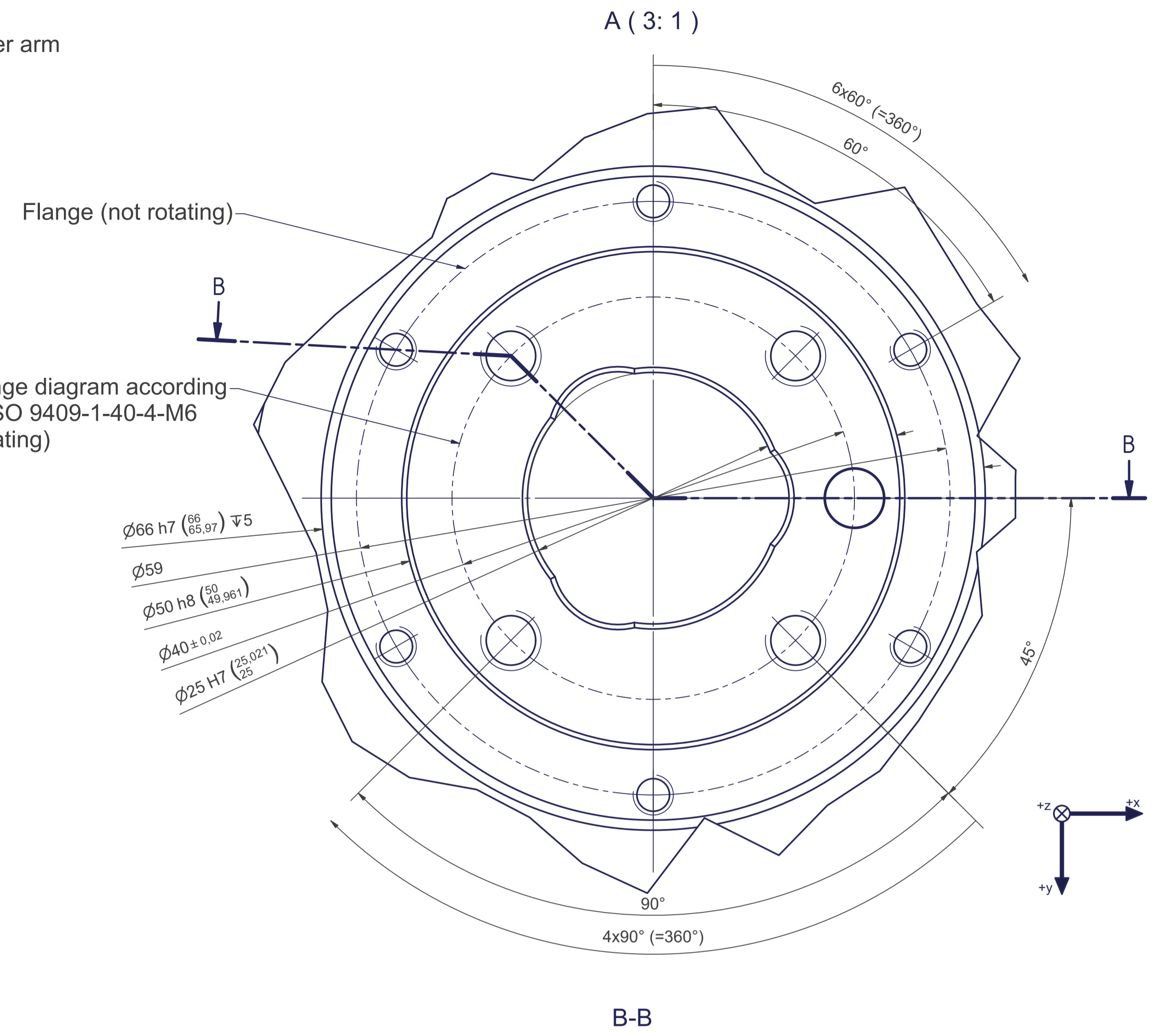

Flange diagram according
to ISO 9409-1-40-4-M6
(rotating)

B-B

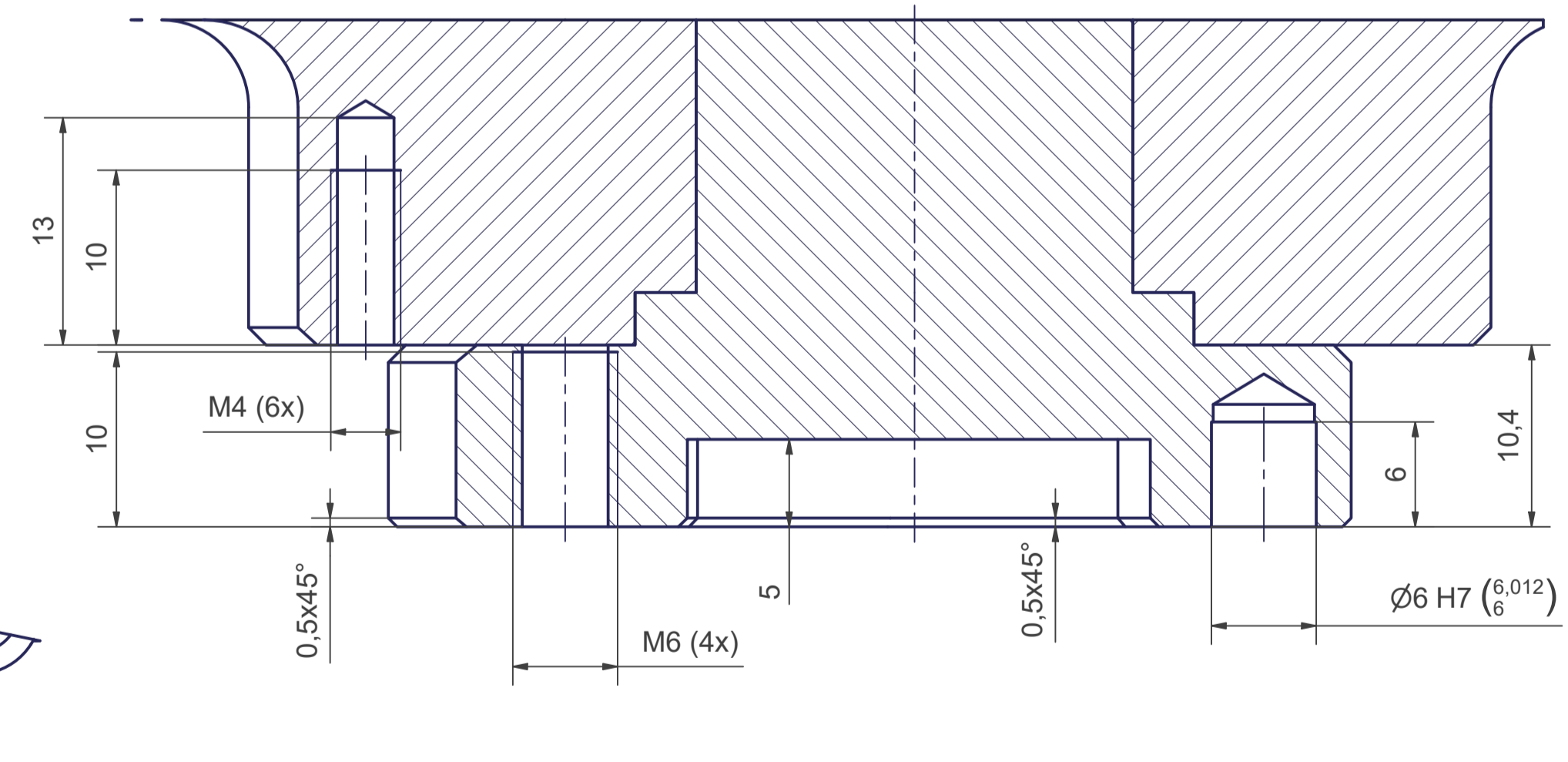
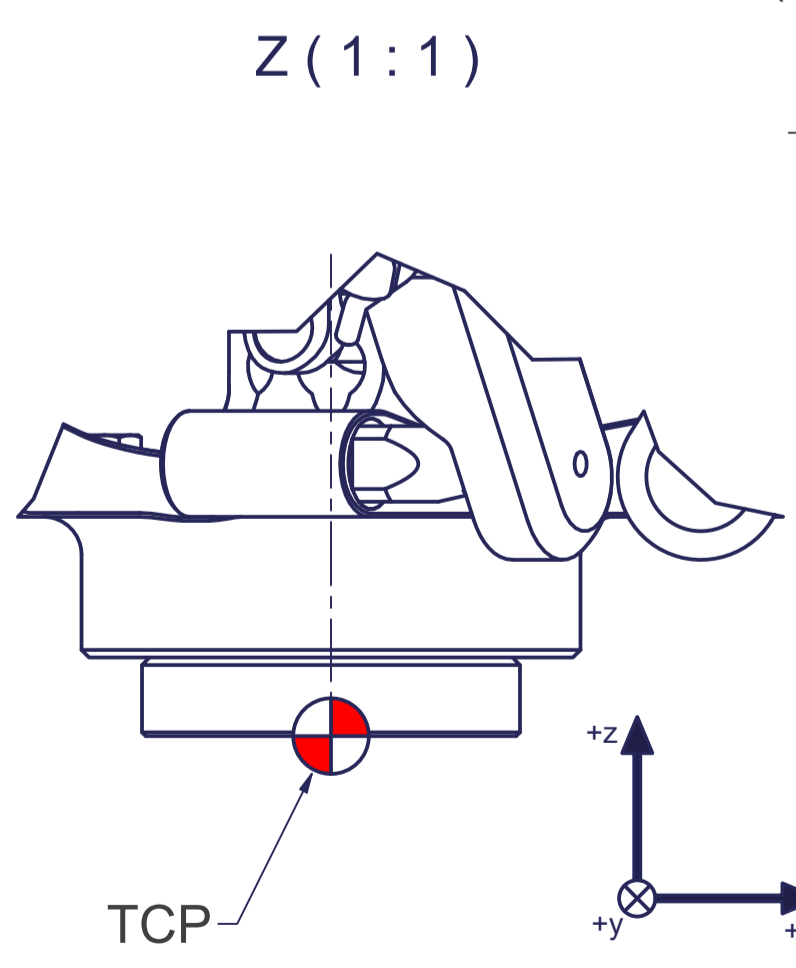

m= kg	A	p= bar
proj. storage surface = m²		v= l/min
First angle projection		P= kW
		U= V / Hz / Ph
		I _{max} = A
		autonox lean line

12 11 10 9 8 7 6 5 4 3 2 1

○ Thread holes for screws M12 are coloured green.
The tightening torque for these screws (strength class 8.8) is 41 Nm.

● Drilling holes for location pins are filled red.
Recommended dimensions for locating pins: $\varnothing 12 \text{ h}8 \left(\begin{smallmatrix} 12 \\ 11,973 \end{smallmatrix} \right)$

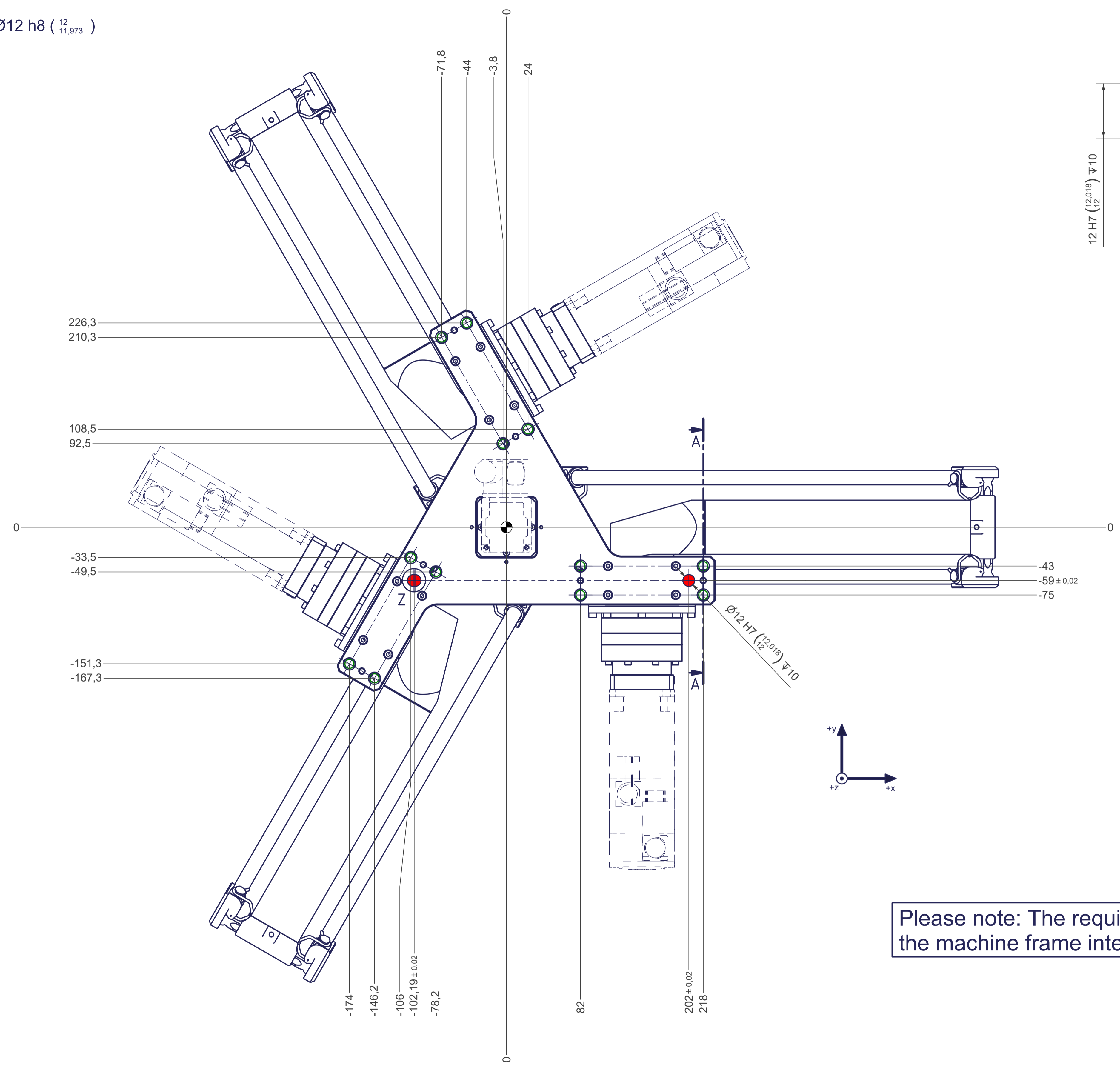
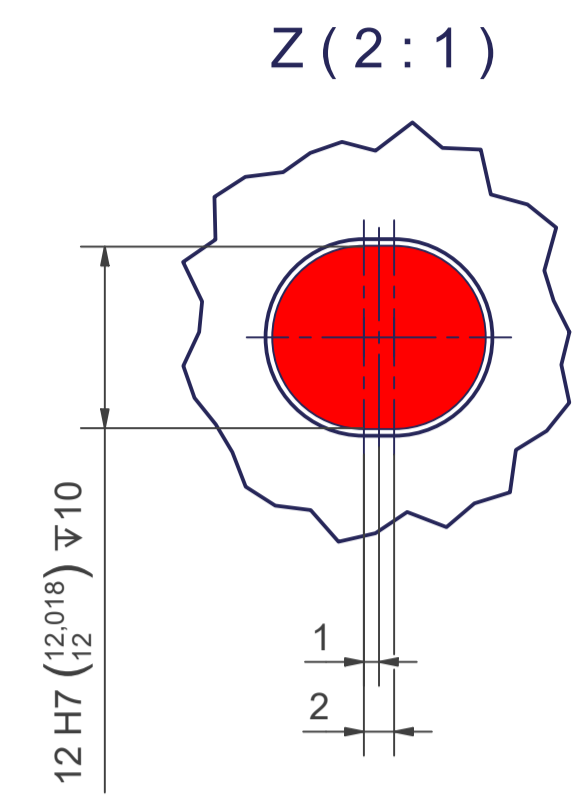

12 11 10 9 8 7 6 5 4 3 2 1