

Connecting dimensions,
valid for article number A_00095.01-T2

m= kg	A	p= bar
proj. storage surface = m²		∇ = l/min
First angle projection	P= kW	U= V / Hz / Ph
	U=	Imax= A

12 11 10 9 8 7 6 5 4 3 2 1

- All fastening holes $\varnothing 17,5$ mm for screws M16 (DIN ISO 4014/4017 -8.8) without washers. Fastening holes are coloured red.
- Drilling holes for locating pins are filled red. Recommend dimensions of locating pins: $\varnothing 12$ h6

Z (2:1)

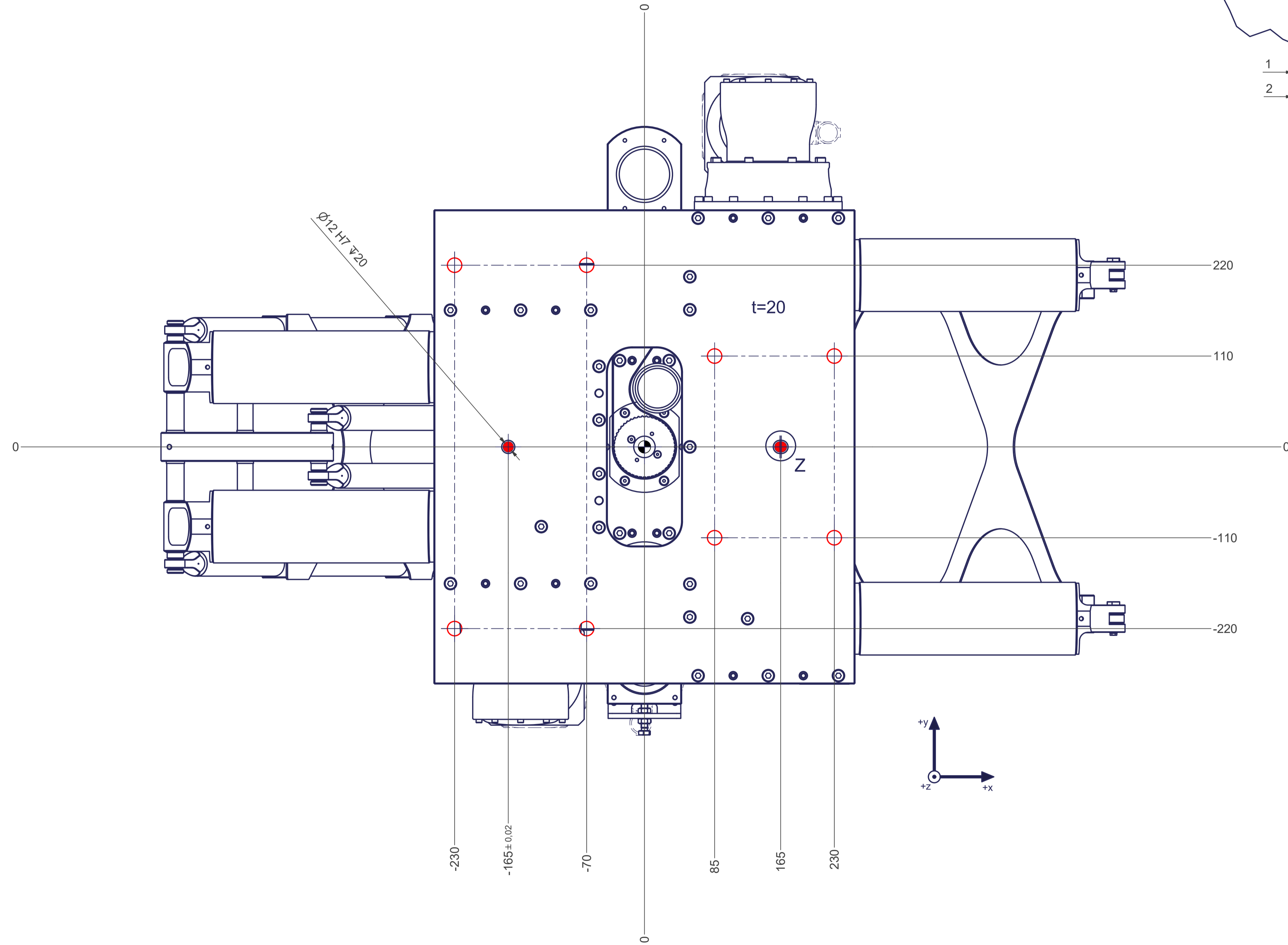
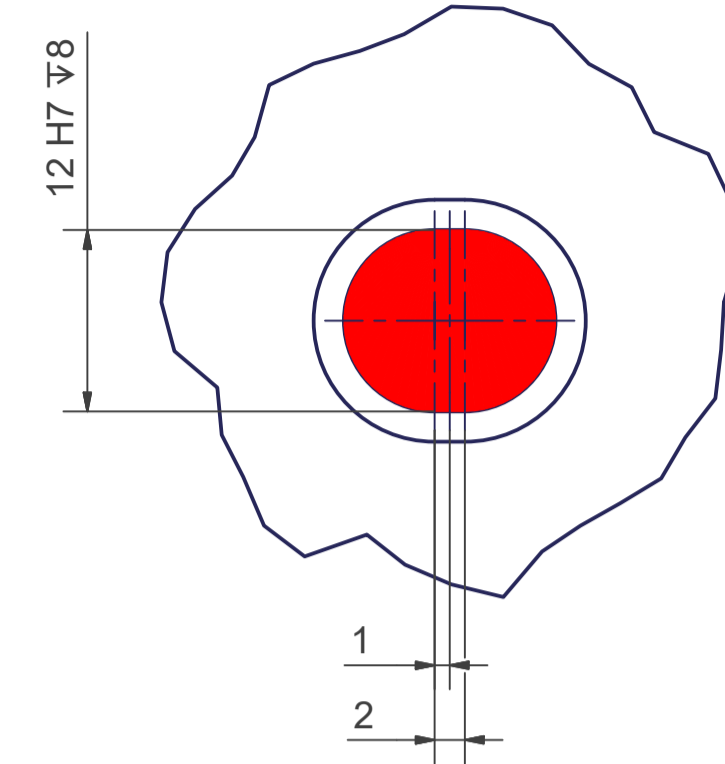

12 11 10 9 8 7 6 5 4 3 2 1