

12 11 10 9 8 7 6 5 4 3 2 1

- Thread holes for screws M6 are coloured red.
The tightening torque for these screws (strength class 8.8) is 4,8 Nm.
- Thread holes for screws M12 are coloured green.
The tightening torque for these screws (strength class 8.8) is 41 Nm.
- Drilling holes for location pins are filled red.
Recommended dimensions for locating pins: $\text{Ø}6 \text{ h}8 \left(\begin{smallmatrix} 6 \\ 5,982 \end{smallmatrix} \right)$

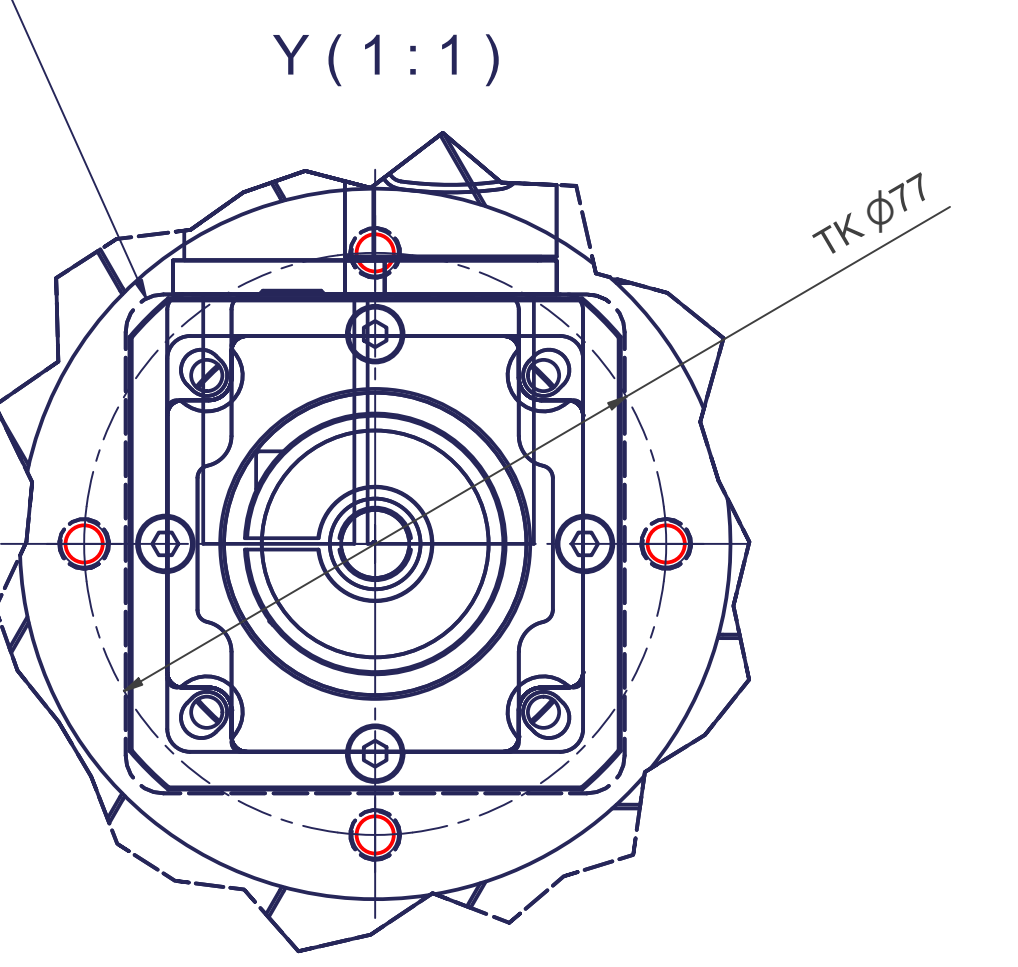
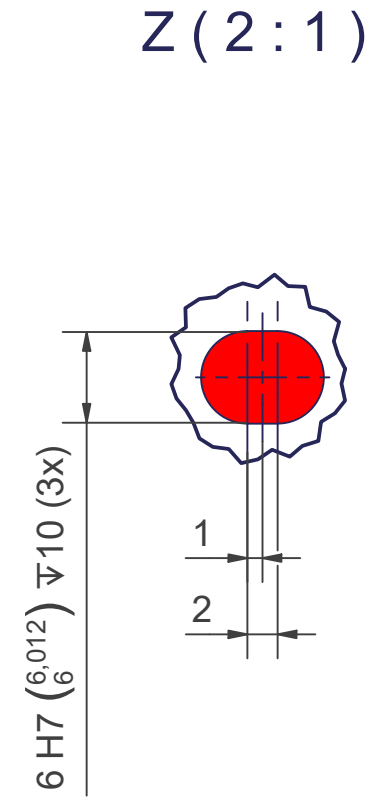
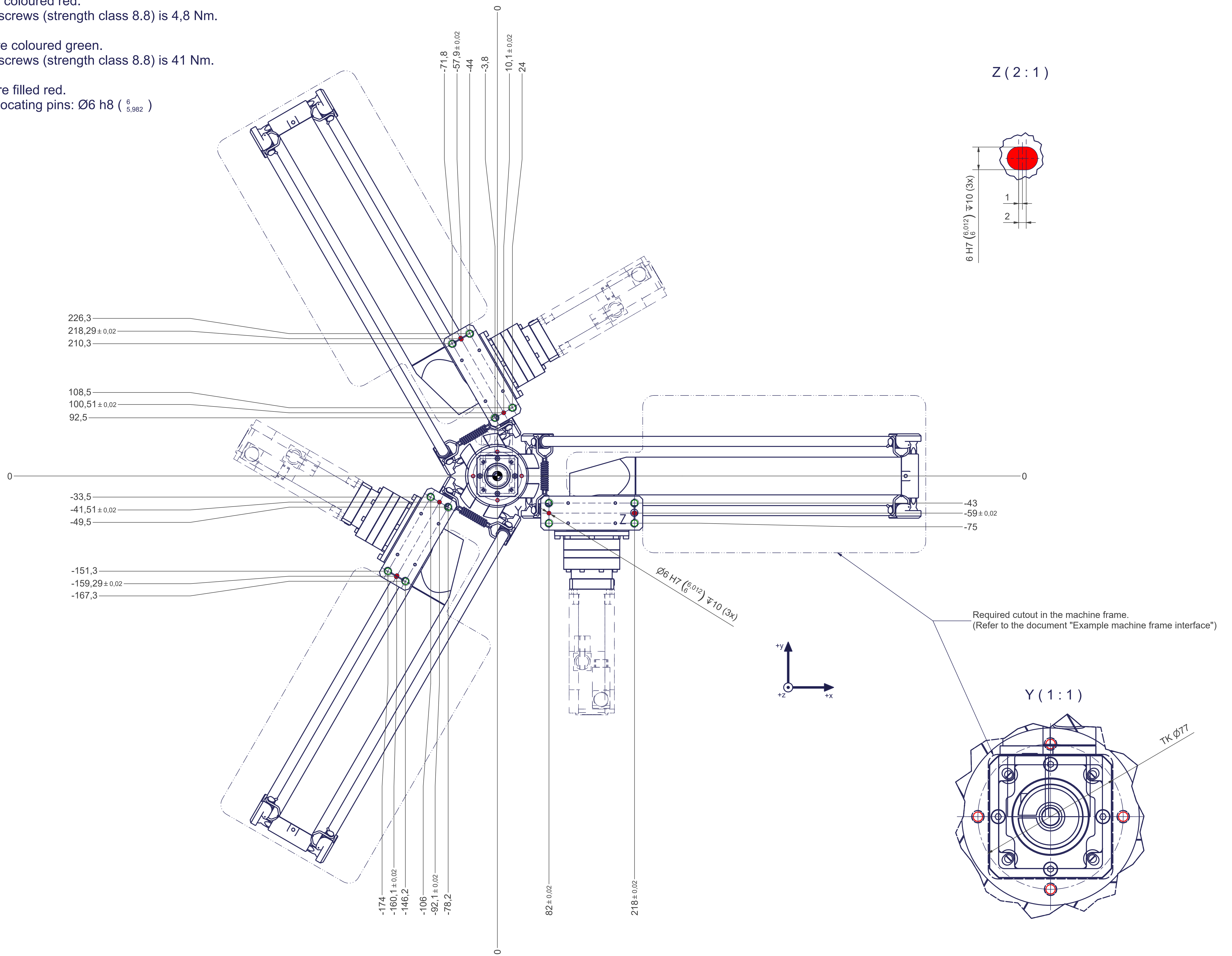

12 11 10 9 8 7 6 5 4 3 2 1