

m= kg	A	p= bar
proj. storage surface = m ²		v= l/min
First angle projection		P= kW
		U= V / Hz / Ph
		I _{max} = A

Connecting dimensions, valid for article number A_00085-01

12 11 10 9 8 7 6 5 4 3 2 1

- All fastening holes $\varnothing 13,5$ for screws M12 (DIN ISO 4014/4017 -8.8) without washers. Fastening holes are coloured red.
- Drilling holes for locating pins are filled red. Recommended dimensions of locating pins: $\varnothing 12$ h6

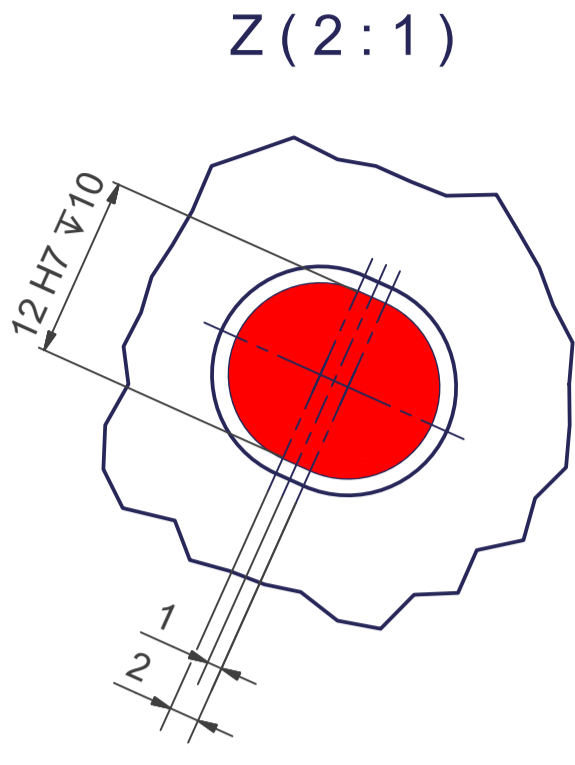
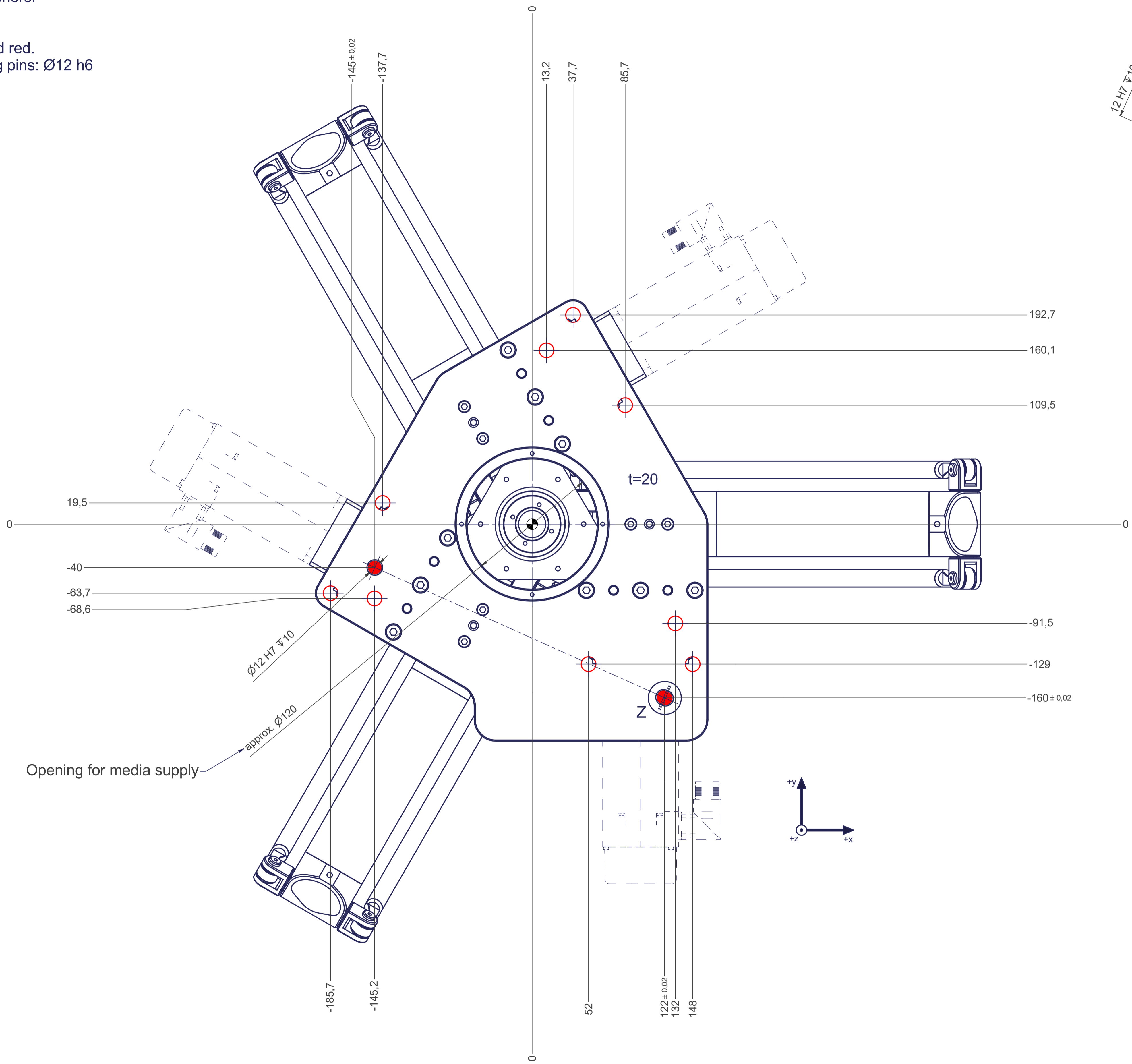

12 11 10 9 8 7 6 5 4 3 2 1