



Connecting dimensions,
valid for article number A_00810-01

m= kg	A	p= bar
proj. storage surface = m²		v̇= l/min
First angle projection	P= kW	
	U= V / Hz / Ph	
	Imax= A	

12 11 10 9 8 7 6 5 4 3 2 1

-  All fastening holes $\varnothing 17,5$ mm for screws M16 (DIN ISO 4014/4017 -8.8) without washers. Fastening holes are coloured red.
-  Fastening holes filled blue are difficult to access. We recommend using fastening holes coloured red.
-  Drilling holes for locating pins are filled red. Recommend dimensions of locating pins: $\varnothing 12$ h6.

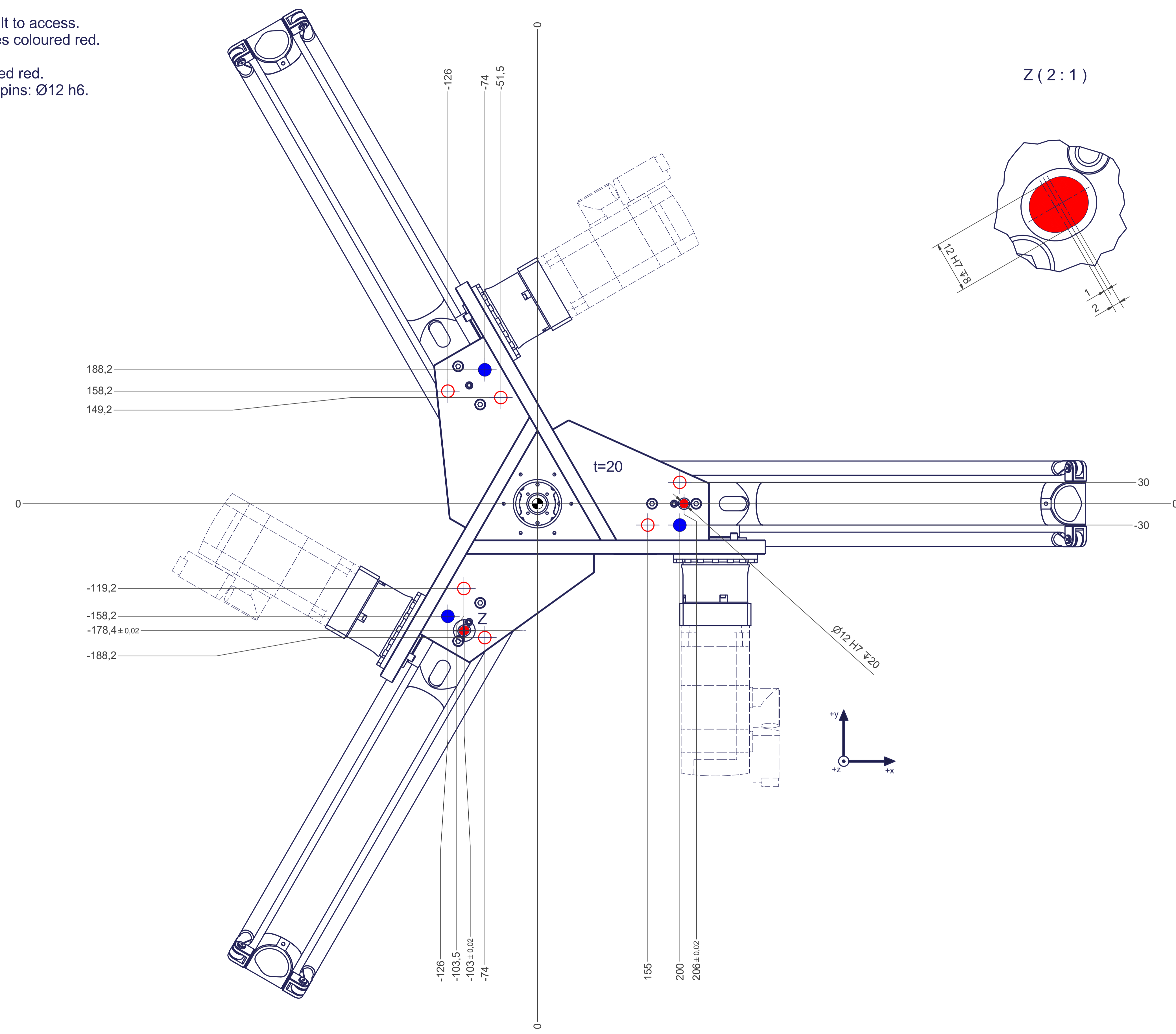

12 11 10 9 8 7 6 5 4 3 2 1