

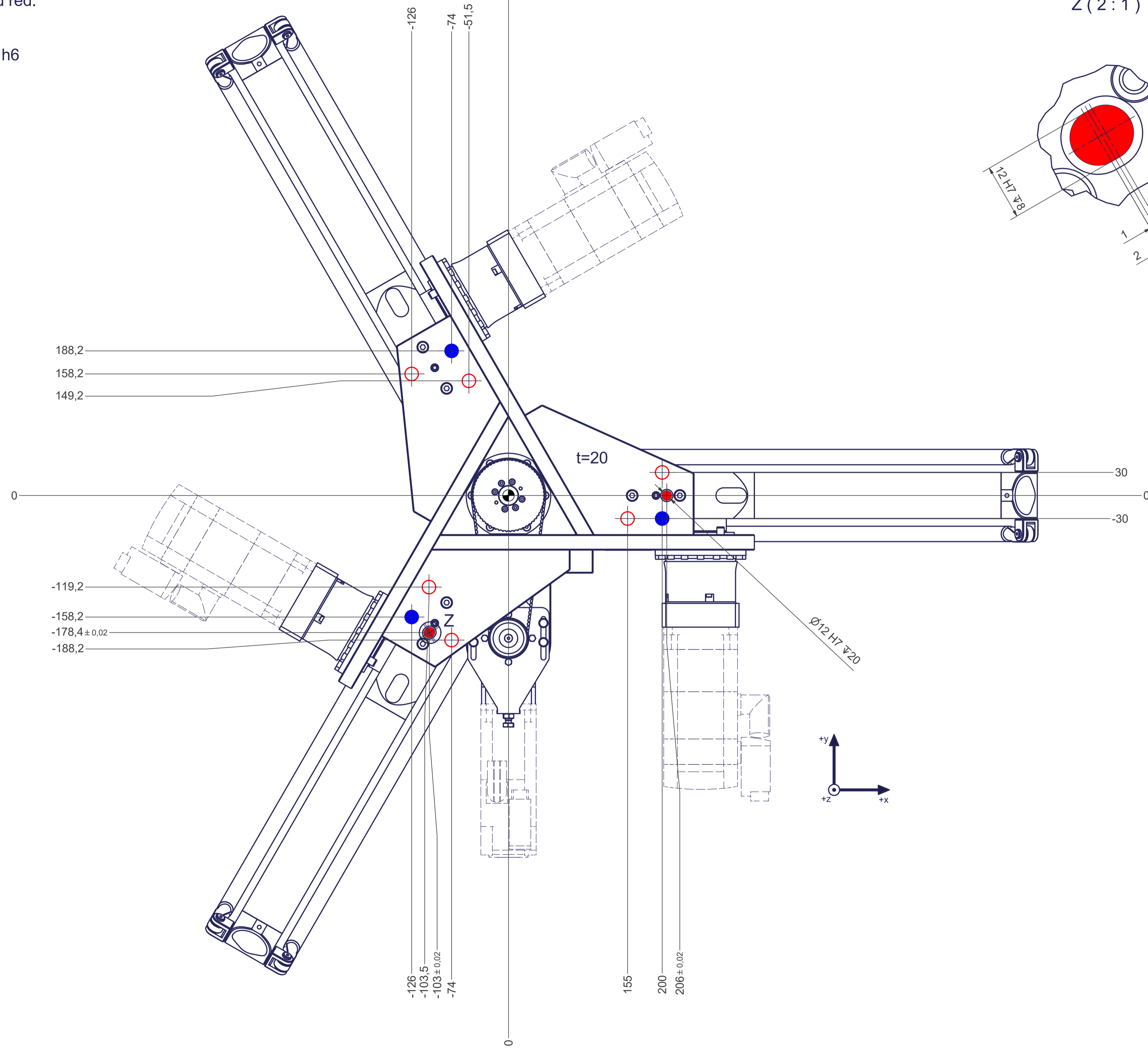

1 2 3 4 5 6 7 8 9 10 11 12

- All fastening holes  $\varnothing 17,5$  mm for screws M16 (DIN ISO 4014/4017 -8.8) without washers. Fastening holes are coloured red.
- Fastening holes filled blue are difficult to access. We recommend using fastening holes coloured red.
- Drilling holes for locating pins are filled red. Recommend dimensions of locating pins:  $\varnothing 12$  h6

Z (2:1)

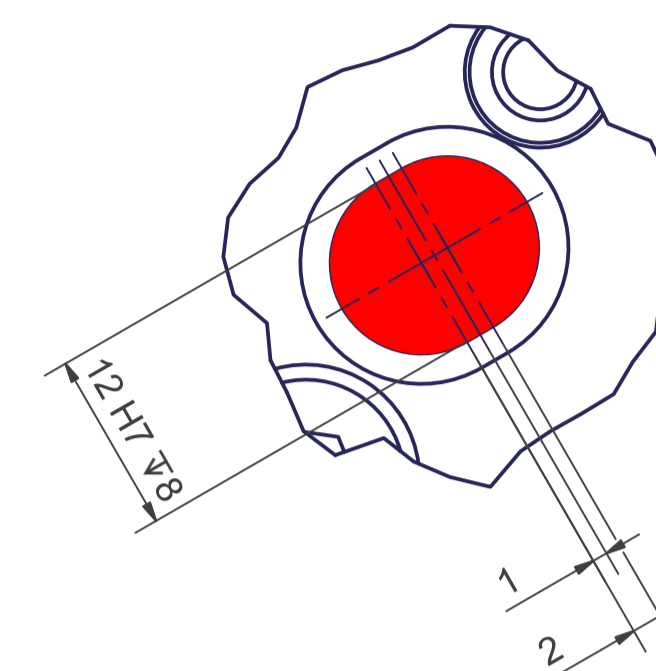

1 2 3 4 5 6 7 8 9 10 11 12

A B C D E F G H

A B C D E F G H