

A (2:1)

4x90° (=360°)

90°

Ø57 ± 0.02

B-B

Z (1:2)

Ø800

Ø830

Ø1010

TCP

m= kg	A	p= bar
proj. storage surface = m²		v̇= l/min
First angle projection	P= kW	
	U= V / Hz / Ph	
	Imax= A	

Connecting dimensions, valid for article numbers A\_00703 and A\_00892

12

11

10

9

8

7

6

5

4

3

2

1

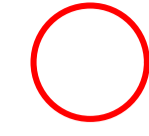

All fastening holes  $\varnothing 13,5$  for screws M12 (DIN ISO 8100 -A2) without washers. Fastening holes are coloured red.

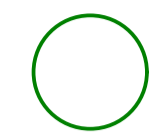

Thread holes for screws M12 are coloured green. The tightening torque for these screws (strength class 8.8) is 117 Nm.

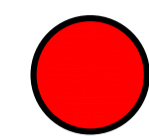

Drilling holes for locating pins are filled red.

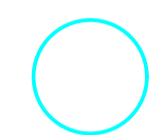

Openings for the cable management are coloured turquoise.

Z (2:1)

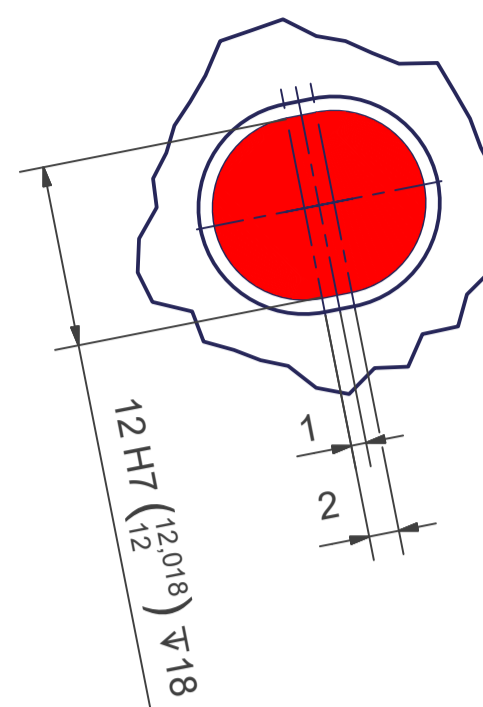

Y (2:1)

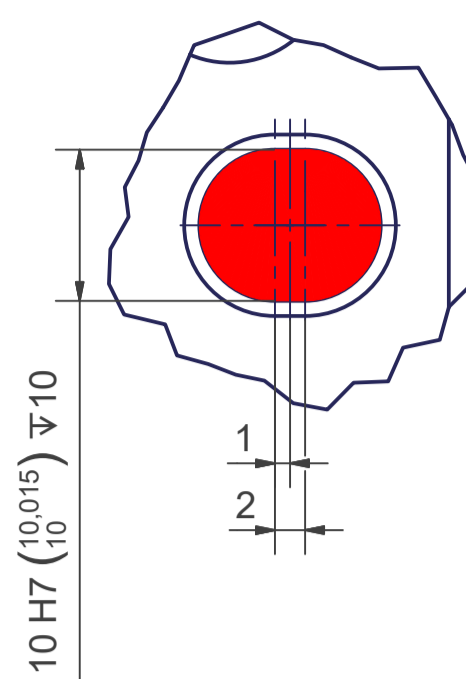

X (2:1)

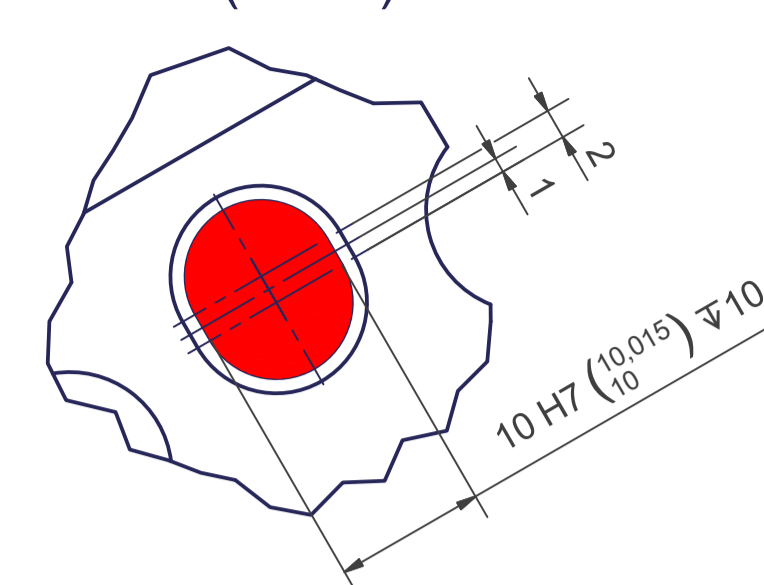

W (2:1)

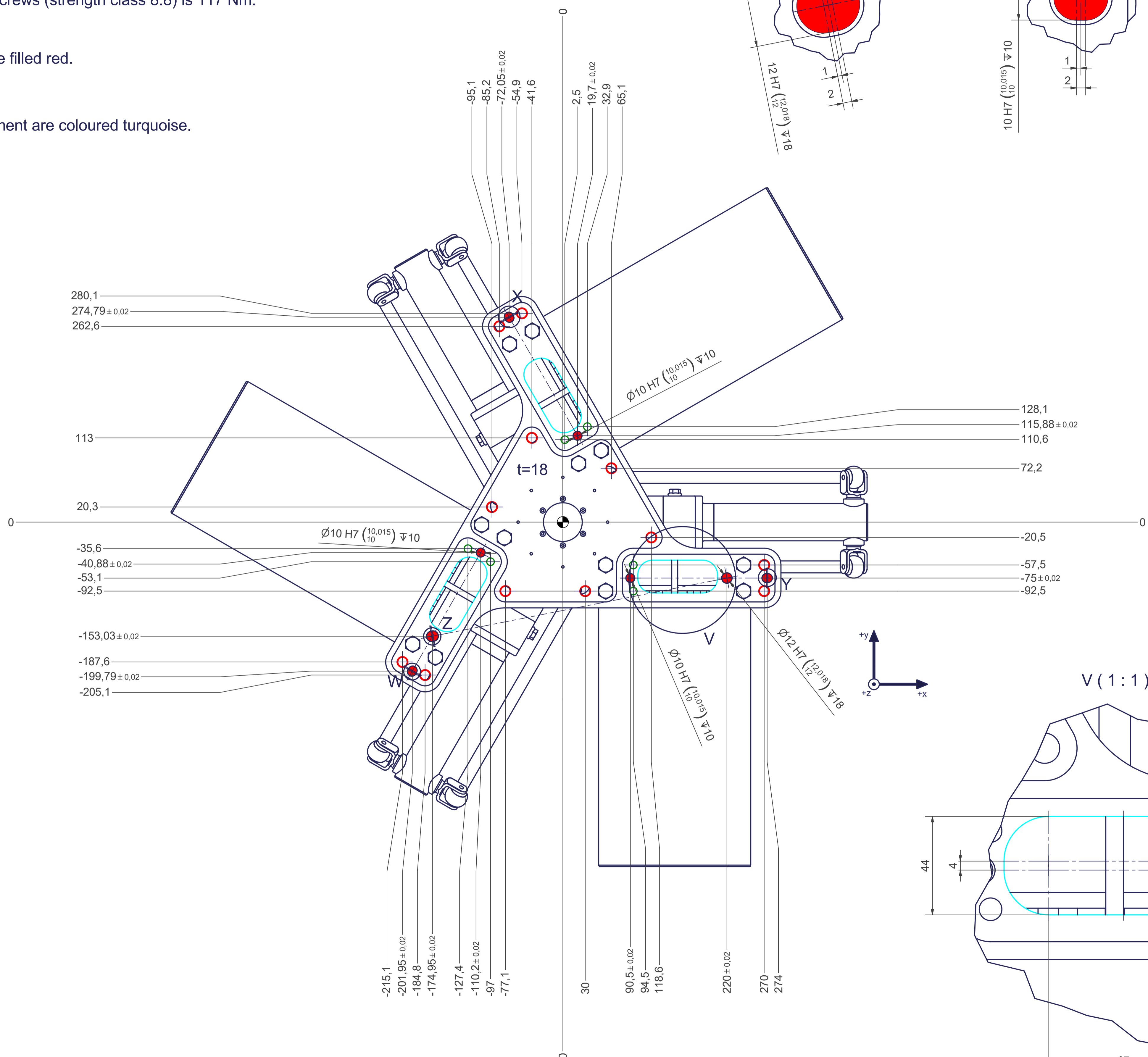
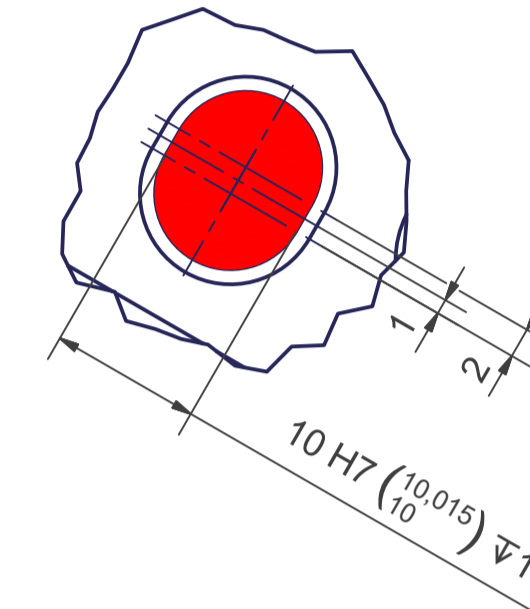

V (1:1)

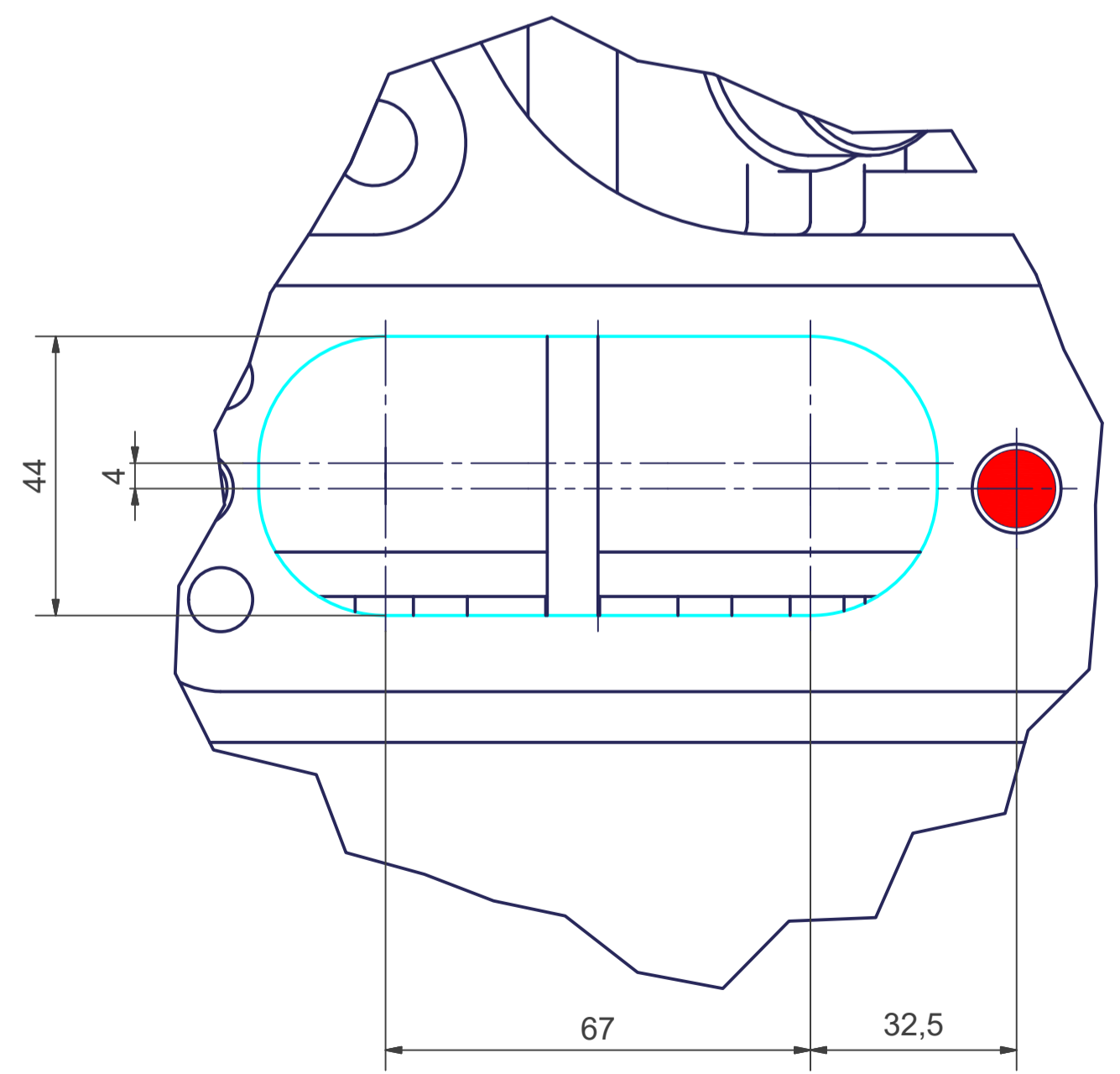

12

11

10

9

8

7

6

5

4

3

2

1