

Tool Center Point
TCP (on the plane of the flange)

TCP - working range

Interference contour
from machine body

Maximum interference contour

Connecting dimensions,
valid for article numbers A_00706 and A_00891

m= kg	A	p= bar
proj. storage surface = m ²	P= kW	\dot{V} = l/min
First angle projection	U= V / Hz / Ph	
	lmax= A	

12

11

10

9

8

7

6

5

4

3

2

1

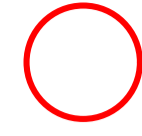

All fastening holes $\varnothing 13,5$ for screws M12 (DIN ISO 8100 -A2) without washers. Fastening holes are coloured red.

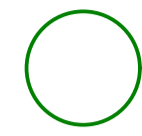

Thread holes for screws M12 are coloured green. The tightening torque for these screws (strength class 8.8) is 117 Nm.

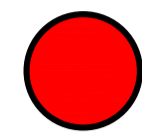

Drilling holes for locating pins are filled red.

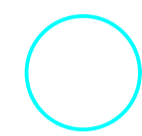

Openings for the cable management are coloured turquoise.

Z (2:1)

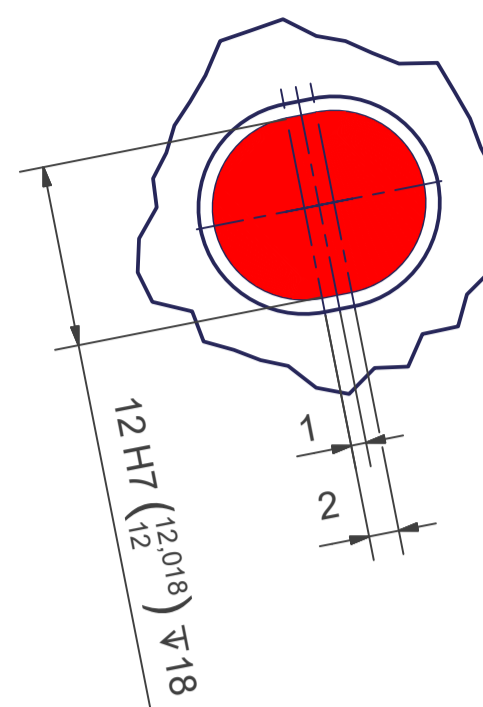

Y (2:1)

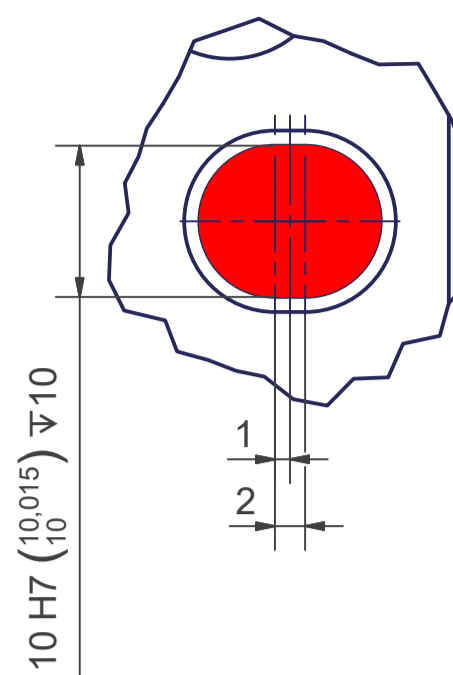

X (2:1)

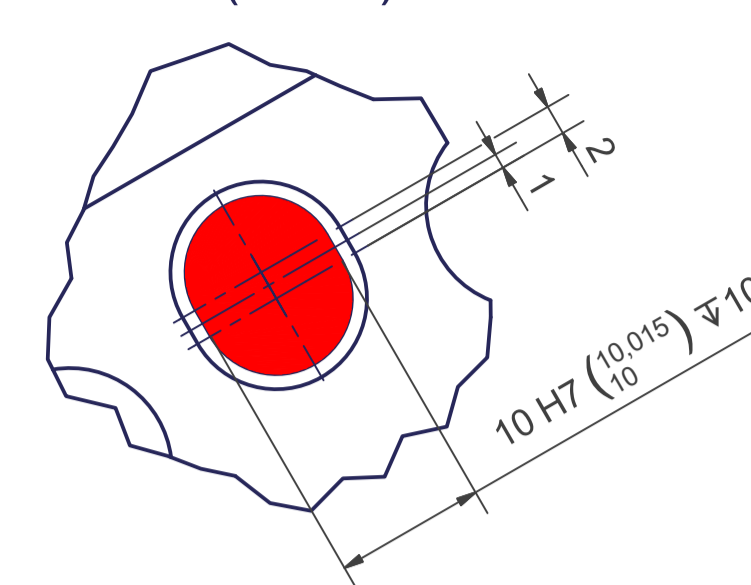

W (2:1)

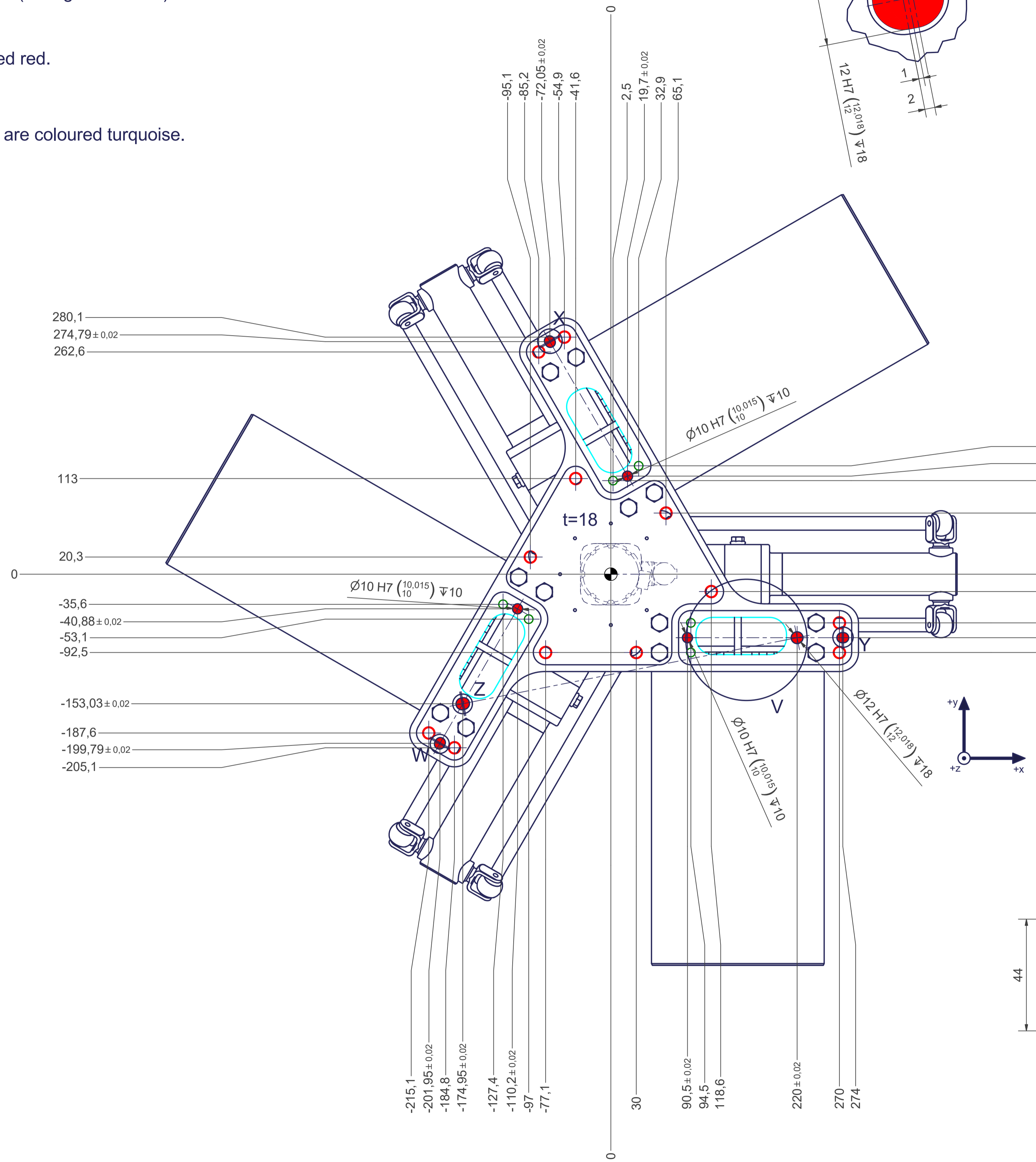
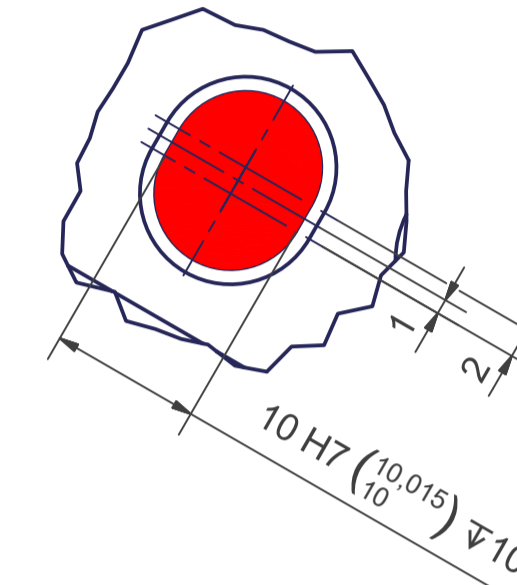

V (1:1)

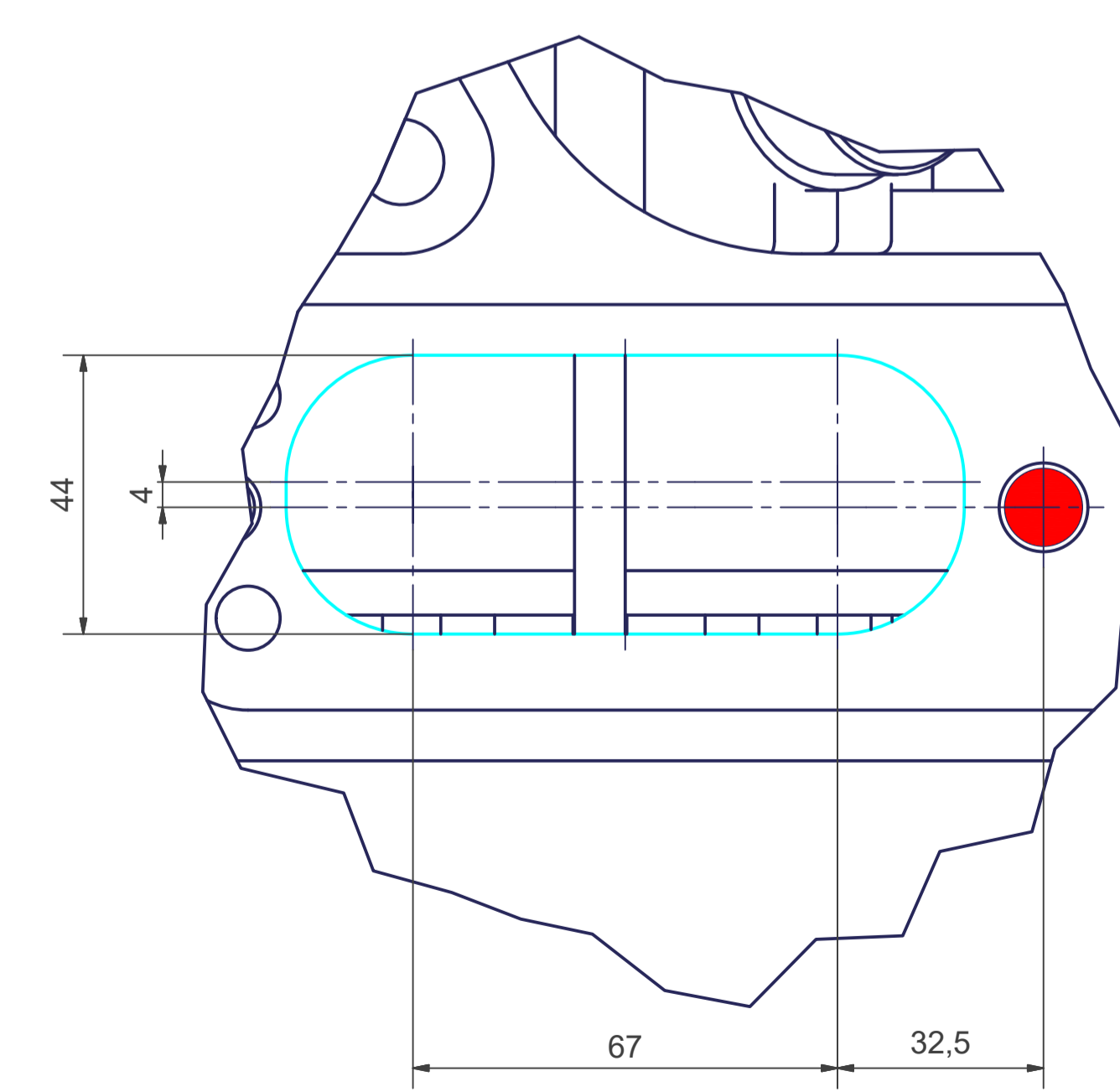

12

11

10

9

8

7

6

5

4

3

2

1