

In Option:  
With vacuum in the 4th axis (MT\_BGR00019553)

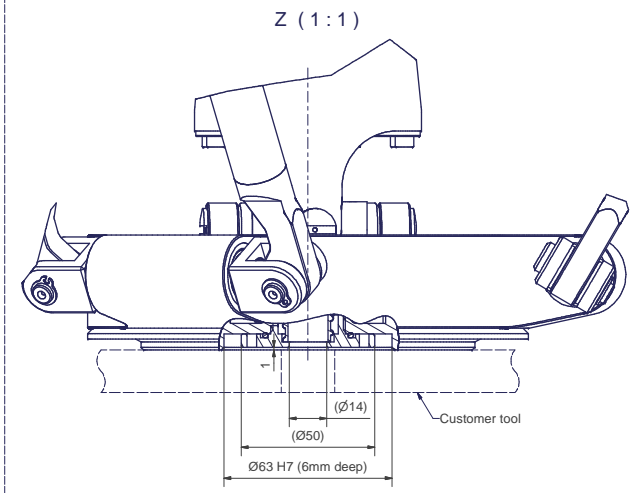

m= kg	A	p= bar
proj. storage surface = m²	P= kW	v= l/min
	U= V / Hz / Ph	
	I <sub>max</sub> = A	

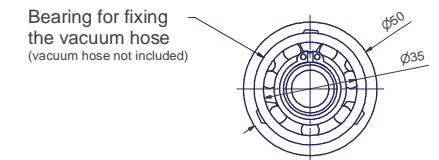
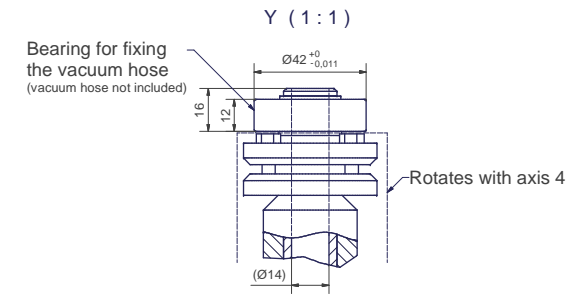