



Rev_02

Connecting dimensions,
valid for article number A_00900-T1

m= kg	A	p= bar
proj. storage surface = m ²		∇ = l/min
First angle projection	P= kW	U= V / Hz / Ph
	U=	Imax= A

A_00900-T1

12 11 10 9 8 7 6 5 4 3 2 1

-  All fastening holes $\varnothing 22$ for screws M20 (DIN ISO 4014/4017 -8.8) without washer. Fastening holes are coloured red.
-  Drilling holes for locating pins are filled red. Recommended dimensions of locating pins: $\varnothing 12$ h6
-  Thread holes for screws M20 are coloured green. The tightening torque for these screws (strength class 8.8) is 170 Nm.

Z (2:1)

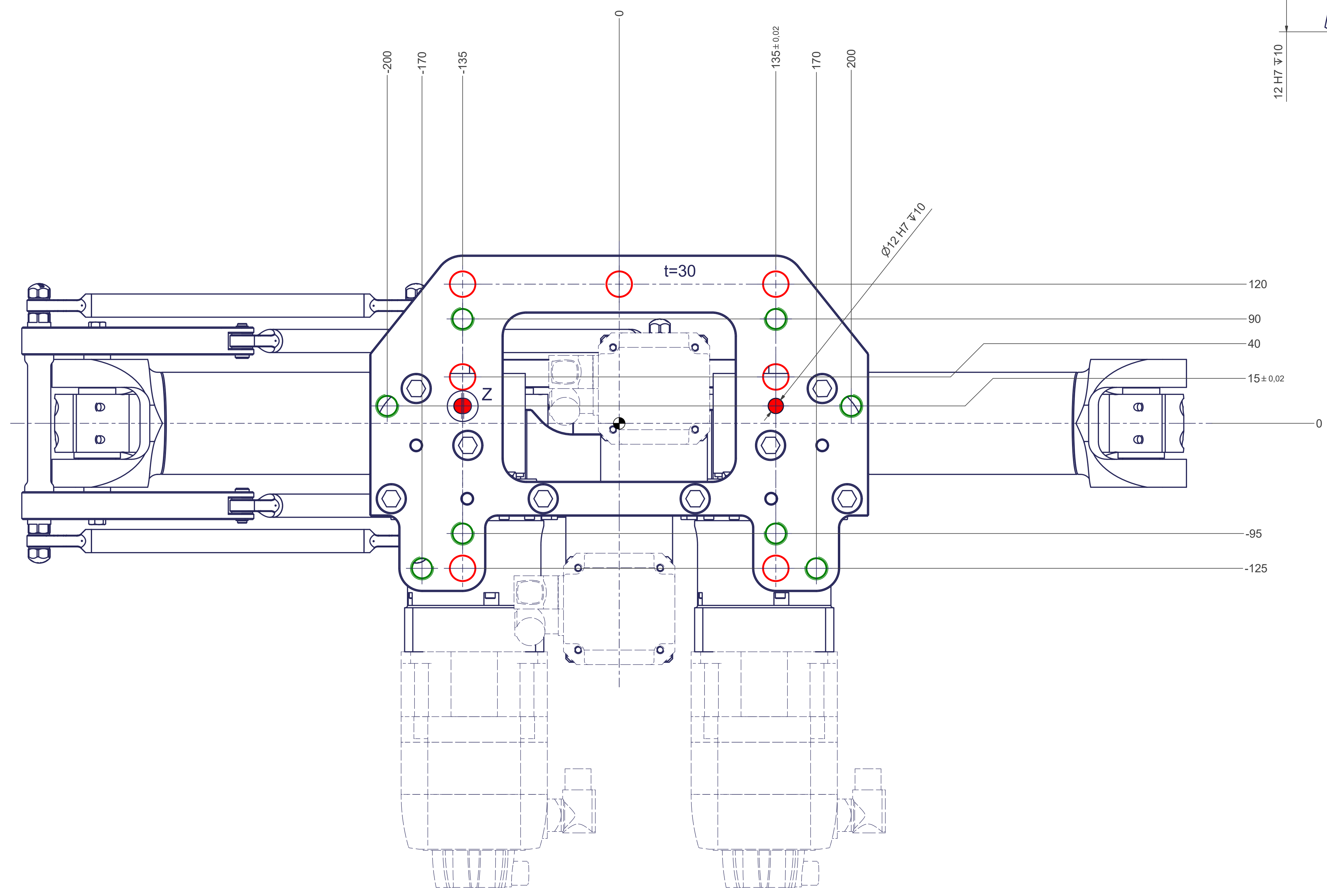
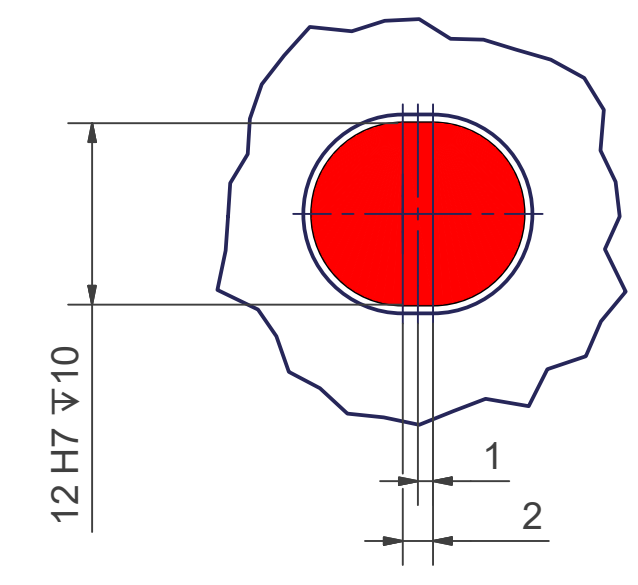

12 11 10 9 8 7 6 5 4 3 2 1