

Tool Center Point  
TCP (on the plane of the flange)

TCP - working range

Depending on the drive type

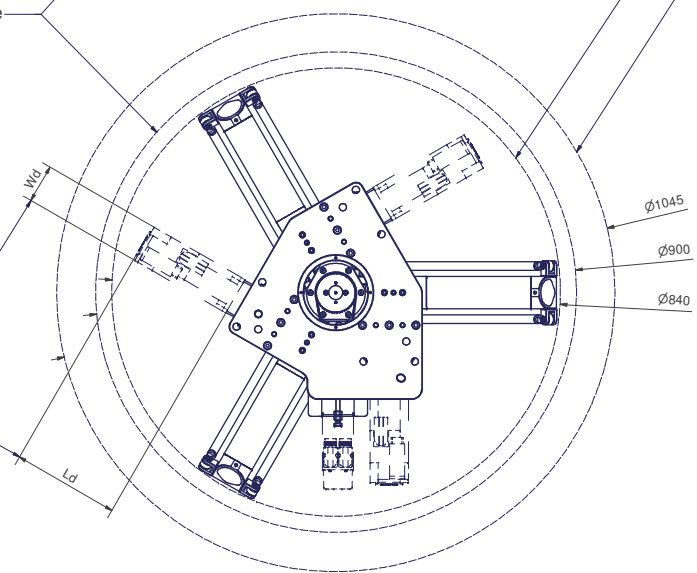

Interference contour  
from machine body

Maximum interference  
contour

Valid for article numbers  
A\_00088-02, A\_00820.01

m= kg	A	p= bar
proj. Stellfläche= m <sup>2</sup>	P= kW	v= l/min
U= V / Hz / Ph	I <sub>max</sub> = A	

12 11 10 9 8 7 6 5 4 3 2 1

○ All fastening holes  $\varnothing 13,5\text{mm}$  for screws M12 (DIN ISO 4014/4017 -8.8) without washers. Fastening holes are coloured red.

● Drilling holes for locating pins are filled red.

H  
G  
F  
E  
D  
C  
B  
A

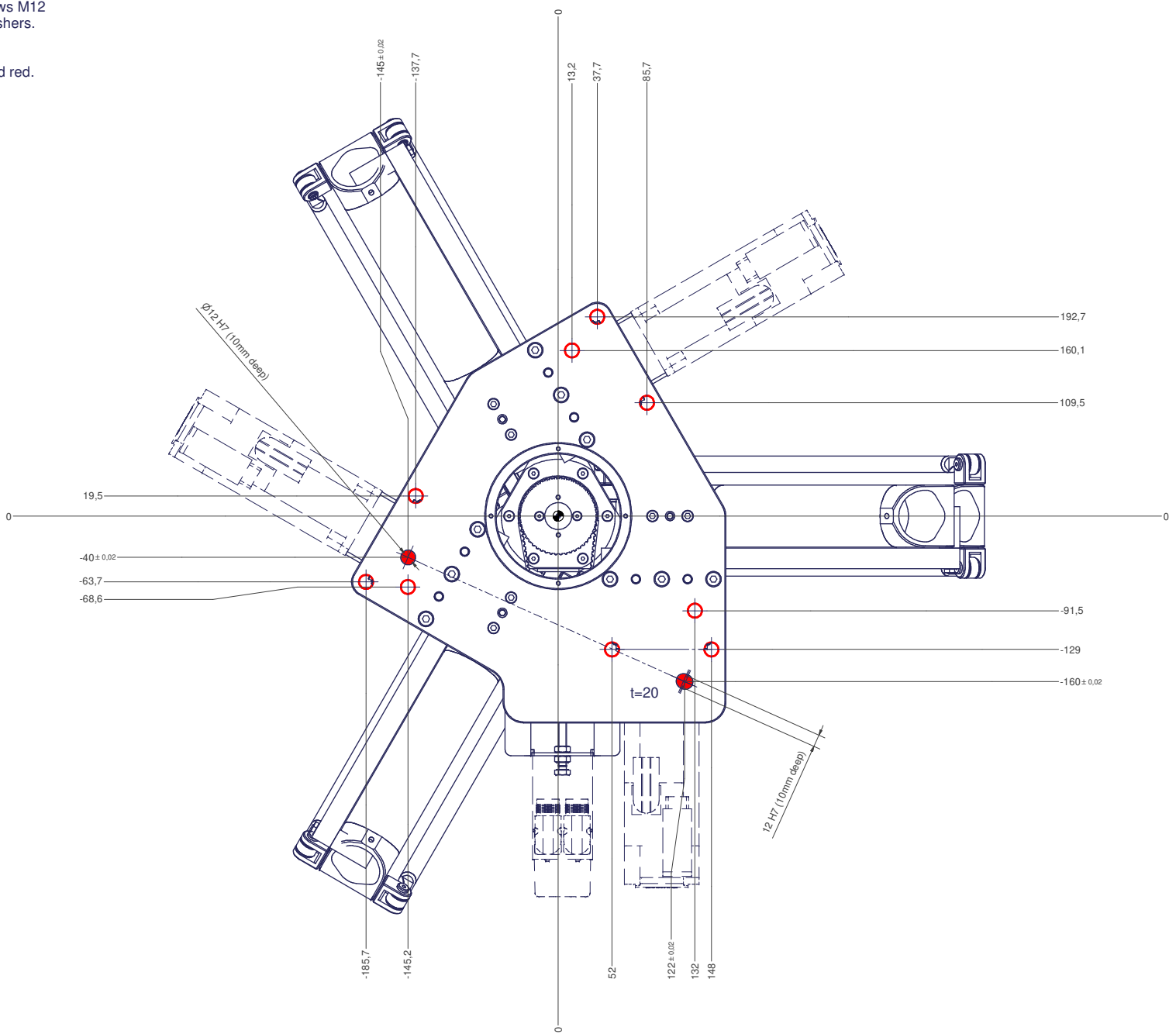

12 11 10 9 8 7 6 5 4 3 2 1