

DuoPod RVS2-ATS-750-3kg

Article number: A_00911-ATS-FO

Lubricant variant: Food-grade lubricants (FO)

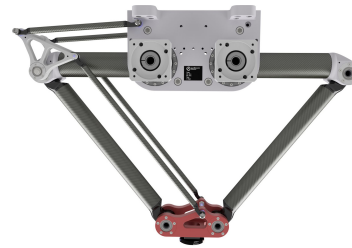

Description:

This type of robot is based on the principle of parallel kinematics. All drives are mounted in a fixed position on the robot head. Motor cables are not moved. The robot has two (2) translational degrees of freedom.

Scope of delivery:

Robot mechanics incl. gearbox, Servo motor adapter, Threaded protection caps, Transport and packing instructions

Connecting dimensions:

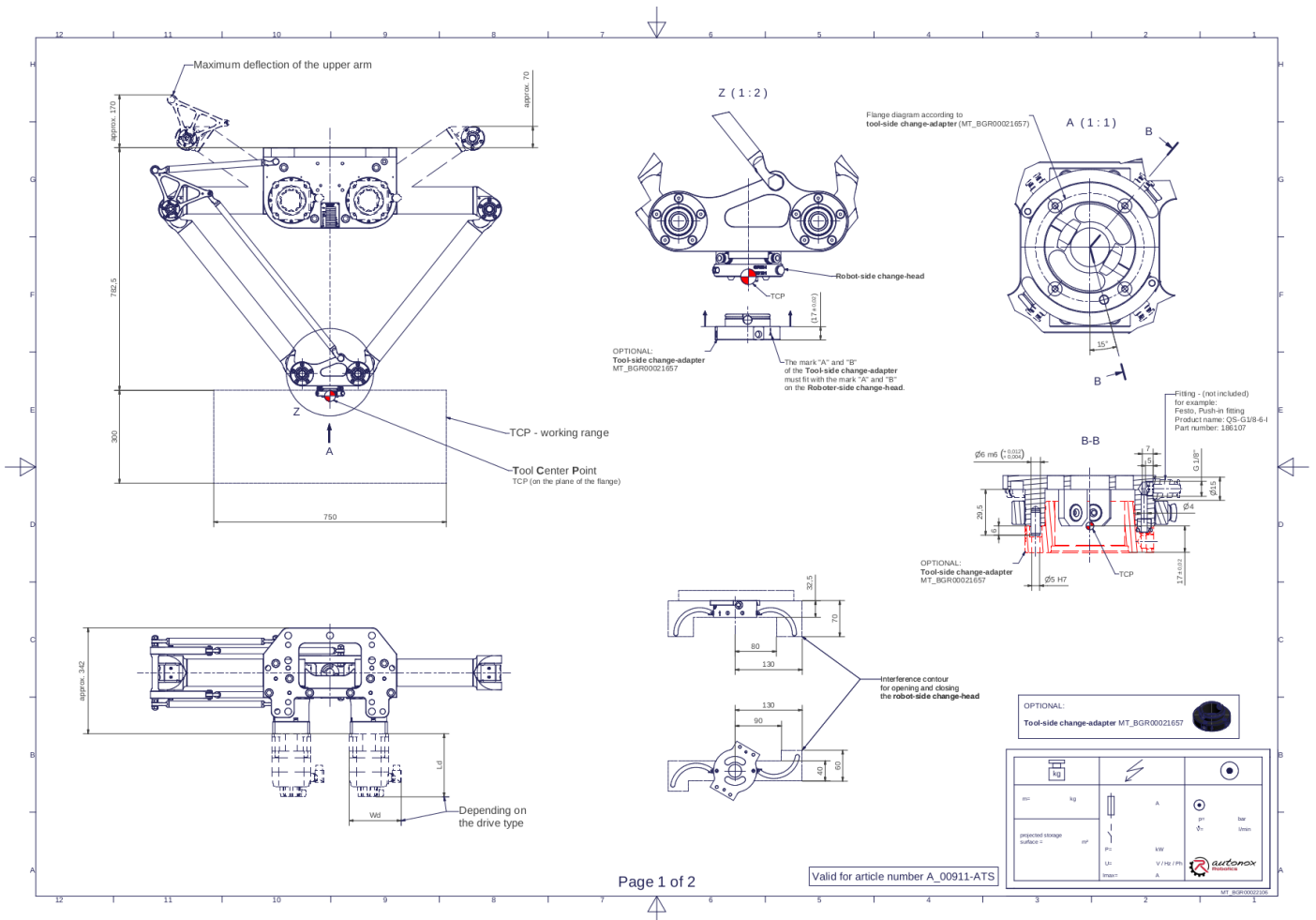

Downloads: [Connecting dimensions \(PDF\)](#), [3D model \(STP\)](#), [3D model \(PDF\)](#)

We refer to our [General Terms of Sale and Supply](#), [Terms of use](#) and [Disclaimer and Copyright notices](#).

Technical specifications:

Field of application	Standard (not hygienic)
Kinematics	Parallel
Translatory Degrees of Freedom (X,Y,Z)	2
Rotational Degrees of Freedom (α, β, γ)	0
Nominal payload [kg lbs] *	3 6.6
Working area-width [mm in]	750 29.5
Working height outside [mm in]	300 11.8
Working height center [mm in]	370 14.6
Manual tool changing system ATS	Fourfold media transmission (Compressed air 6 bar 87.0 psi / vacuum -850 mbar -12.3 psi / min. inner- \varnothing : 4 mm 0.16 in)
Bearing type of the arm joints	Roller bearing
Lubricants of the bearings	Food-grade (FO)
Lubricants of the gearboxes	Food-grade (FO)
Cleaning	No high pressure
Ambient temperature [$^{\circ}$ C $^{\circ}$ F]	0 to +40 +32 to +104
Relative humidity level [%]	95 (free of condensation)
Mounting position	Floor, Ceiling, Wall (on request), Angle (on request)
Robot weight without drive engineering (esp. drive) [kg lbs]	50 110.2

* All given values are nominal values (nominal payload referred to a nominal performance) and can vary under realworld conditions depending on the application (tool specifications, load distances, reduction (partly) of the nominal performance when using food-grade lubricants, ...). Please consider our technical data sheets regarding the load capacity.