

# HHD DELTA RL3-T1-1120-3kg

Article number: A\_00881-T1

Lubricant variant: Synthetic lubricants

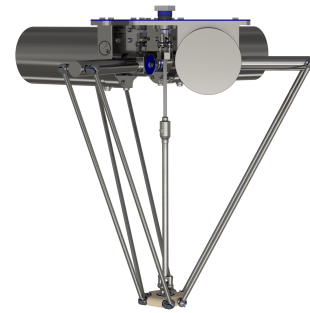

### Description:

This type of robot is based on the principle of parallel kinematics. All drives are mounted in a fixed position on the robot head. Motor cables are not moved. The robot has three (3) translational degrees of freedom.

### Scope of delivery:

Robot mechanics incl. gearbox, Servo motor adapter, Transport and packing instructions

### Connecting dimensions:

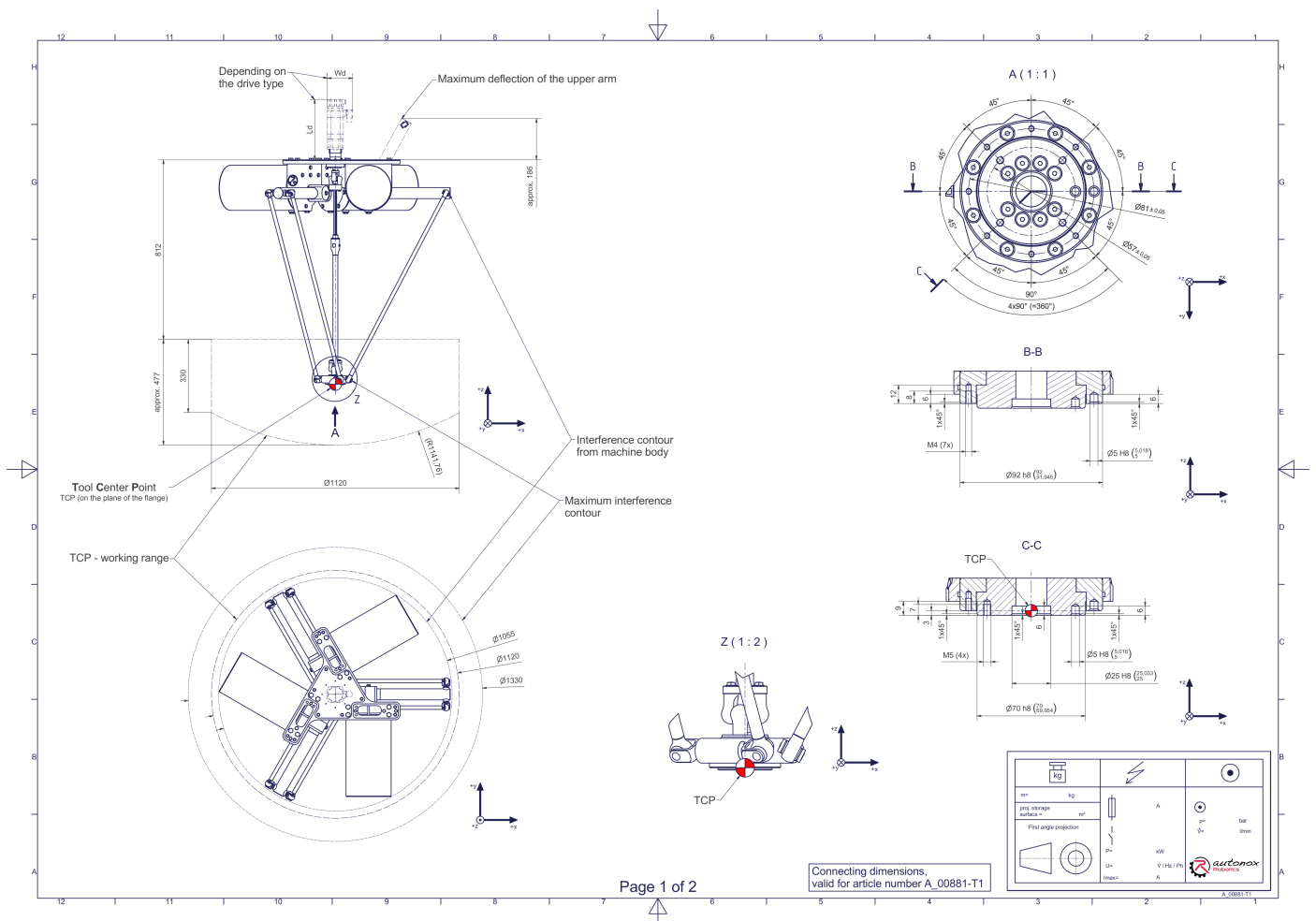

Downloads: [Connecting dimensions \(PDF\)](#), [3D model \(STP\)](#), [3D model \(PDF\)](#)

We refer to our [General Terms of Sale and Supply](#), [Terms of use](#) and [Disclaimer and Copyright notices](#).

## Technical specifications:

Field of application	Hygienic 'HHD'
Kinematics	Parallel
Translatory Degrees of Freedom (X,Y,Z)	3
Rotational Degrees of Freedom ( $\alpha, \beta, \gamma$ )	0
Nominal payload [kg   lbs] *	3   6.6
Working area-diameter [mm   in]	1120   44.1
Working height outside [mm   in]	330   13.0
Working height center [mm   in]	477   18.8
Output type of the tool actuation	Flange (T)
Number of the tool actuation (telescopic shaft(s))	1
Max. acceleration torque of the tool actuation T/TS1 at the output [Nm   in.lbs]	6   53.1
Nominal torque of the tool actuation T/TS1 at the output [Nm   in.lbs]	4,8   42.5
Max. speed of the tool actuation T/TS1 at the output [1/min]	800
Nominal speed of the tool actuation T/TS1 at the output [1/min]	460
Bearing type of the telescopic shaft(s)	Roller bearing
Bearing type of the arm joints	Roller bearing
Lubricants of the bearings	Food-grade (FO)
Lubricants of the gearboxes	Gearbox of the upper arms: Synthetic; gearbox of the telescopic shaft: Food-grade (FO)
Cleaning	Up to 28 bar   406 psi high pressure
Protection class	IP69K
Ambient temperature [°C   °F]	0 to +40   +32 to +104
Relative humidity level [%]	95 (free of condensation)
Mounting position	Ceiling, Wall (on request), Angle (on request)

\* All given values are nominal values (nominal payload referred to a nominal performance) and can vary under realworld conditions depending on the application (tool specifications, load distances, reduction (partly) of the nominal performance when using food-grade lubricants, ...). Please consider our technical data sheets regarding the load capacity.

## Gearbox article number for this robot mechanics:

Function	Article number	Document
Drive of the upper arms	MT_BGR00013366-xx	Operating manual gearbox type 3 (PDF)
Drive of the telescopic shaft for tool actuation T1	MT_WST00104439-xx-FO	Operating manual gearbox type 1 (PDF)