

HHD DELTA RL4-1200-3kg

Article number: A_00873

Lubricant variant: Synthetic lubricants

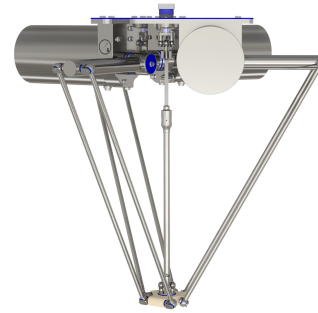

Description:

This type of robot is based on the principle of parallel kinematics. All drives are mounted in a fixed position on the robot head. Motor cables are not moved. The robot has three (3) translational and one (1) rotational degree(s) of freedom.

Scope of delivery:

Robot mechanics incl. gearbox, Servo motor adapter, Transport and packing instructions

Connecting dimensions:

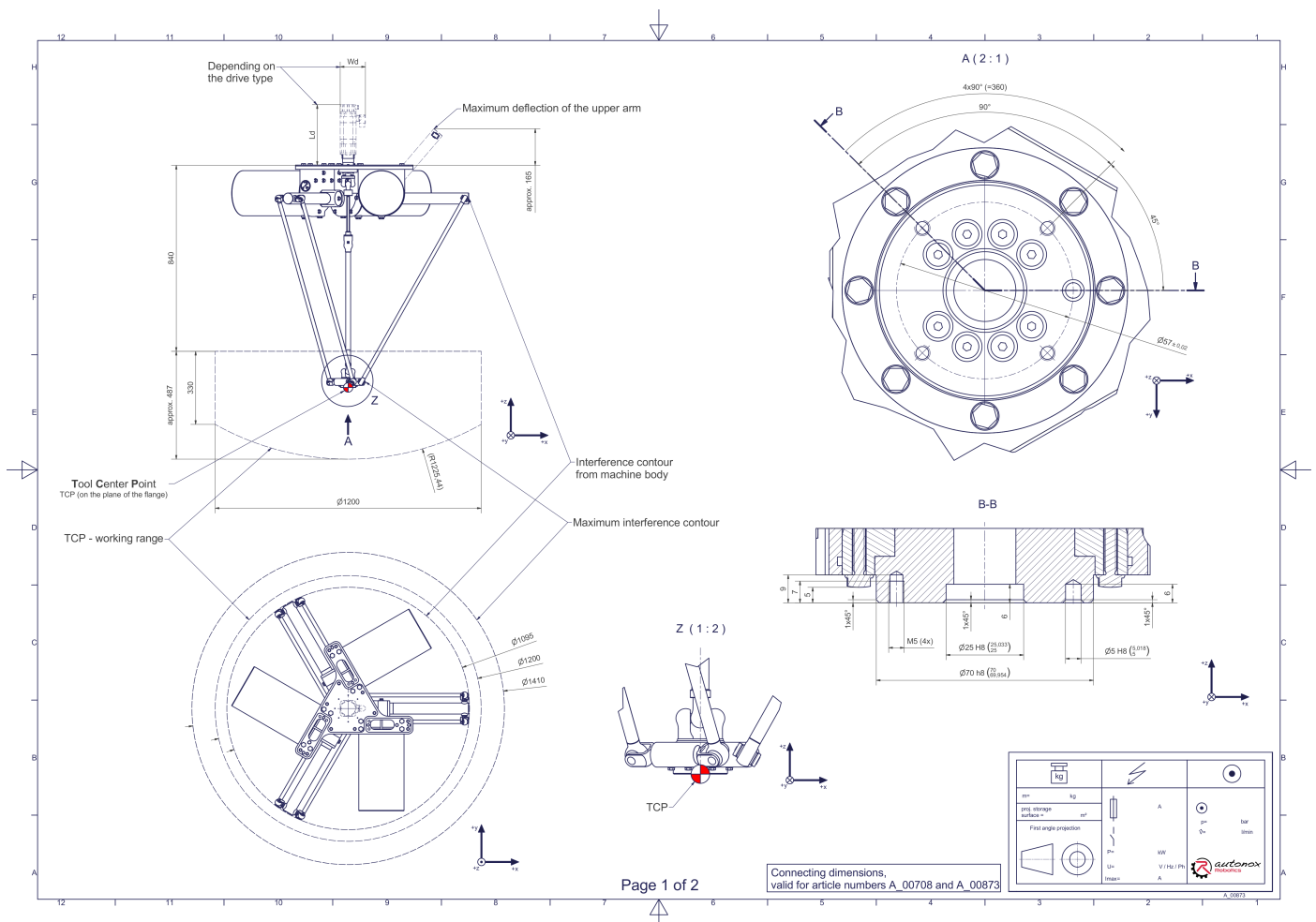

Downloads: [Connecting dimensions \(PDF\)](#), [3D model \(STP\)](#), [3D model \(PDF\)](#)

We refer to our [General Terms of Sale and Supply](#), [Terms of use](#) and [Disclaimer and Copyright notices](#).

Technical specifications:

Field of application	Hygienic 'HHD'
Kinematics	Parallel
Translatory Degrees of Freedom (X,Y,Z)	3
Rotational Degrees of Freedom (α, β, γ)	1
Nominal payload [kg lbs] *	3 6.6
Working area-diameter [mm in]	1200 47.2
Working height outside [mm in]	330 13.0
Working height center [mm in]	487 19.2
Max. acceleration torque of the rotation γ around Z at the output [Nm in.lbs]	6 53.1
Nominal torque of the rotation γ around Z at the output [Nm in.lbs]	4,8 42.5
Max. speed of the rotation γ around Z at the output [1/min]	800
Nominal speed of the rotation γ around Z at the output [1/min]	460
Bearing type of the telescopic shaft(s)	Roller bearing
Bearing type of the arm joints	Roller bearing
Lubricants of the bearings	Food-grade (FO)
Lubricants of the gearboxes	Gearbox of the upper arms: Synthetic; gearbox of the telescopic shaft: Food-grade (FO)
Cleaning	Up to 28 bar 406 psi high pressure
Protection class	IP69K
Ambient temperature [°C °F]	0 to +40 +32 to +104
Relative humidity level [%]	95 (free of condensation)
Mounting position	Ceiling, Wall (on request), Angle (on request)
Robot weight without drive engineering (esp. drive) [kg lbs]	87 191.8

* All given values are nominal values (nominal payload referred to a nominal performance) and can vary under realworld conditions depending on the application (tool specifications, load distances, reduction (partly) of the nominal performance when using food-grade lubricants, ...). Please consider our technical data sheets regarding the load capacity.

Gearbox article number for this robot mechanics:

Function	Article number	Document
Drive of the upper arms	MT_BGR00013366-xx	Operating manual gearbox type 3 (PDF)
Drive of the telescopic shaft for rotation γ around Z	MT_WST00104439-xx-FO	Operating manual gearbox type 1 (PDF)