

# DELTA RL4-1400-1kg

Article number: A\_00864-01

Lubricant variant: Synthetic lubricants



**Description:**

This type of robot is based on the principle of parallel kinematics. All drives are mounted in a fixed position on the robot head. Motor cables are not moved. The robot has three (3) translational and one (1) rotational degree(s) of freedom.

**Scope of delivery:**

Robot mechanics incl. gearbox, Servo motor adapter, Threaded protection caps, Transport and packing instructions

**Connecting dimensions:**

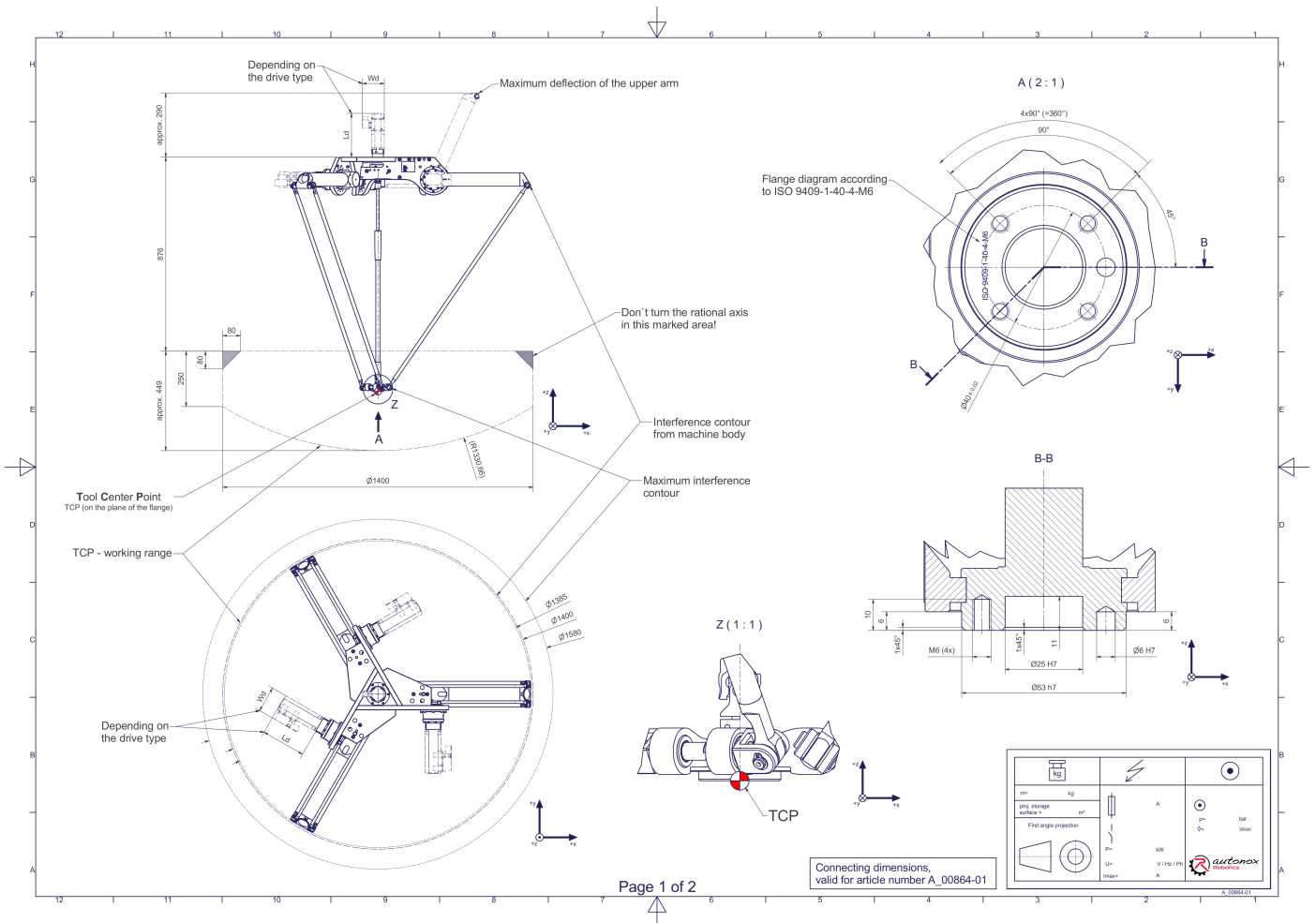

**Downloads:** [Connecting dimensions \(PDF\)](#), [3D model \(STP\)](#), [3D model \(PDF\)](#)

We refer to our [General Terms of Sale and Supply](#), [Terms of use](#) and [Disclaimer and Copyright notices](#).

## Technical specifications:

<b>Field of application</b>	Standard (not hygienic)
<b>Kinematics</b>	Parallel
<b>Translatory Degrees of Freedom (X,Y,Z)</b>	3
<b>Rotational Degrees of Freedom (<math>\alpha, \beta, \gamma</math>)</b>	1
<b>Nominal payload [kg   lbs] *</b>	1   2.2
<b>Working area-diameter [mm   in]</b>	1400   55.1
<b>Working height outside [mm   in]</b>	250   9.8
<b>Working height center [mm   in]</b>	449   17.7
<b>Max. acceleration torque of the rotation <math>\gamma</math> around Z at the output [Nm   in.lbs]</b>	7,2   63.7
<b>Nominal torque of the rotation <math>\gamma</math> around Z at the output [Nm   in.lbs]</b>	6   53.1
<b>Max. speed of the rotation <math>\gamma</math> around Z at the output [1/min]</b>	500
<b>Nominal speed of the rotation <math>\gamma</math> around Z at the output [1/min]</b>	460
<b>Bearing type of the telescopic shaft(s)</b>	Roller bearing
<b>Bearing type of the arm joints</b>	Roller bearing
<b>Lubricants of the bearings</b>	Synthetic
<b>Lubricants of the gearboxes</b>	Synthetic
<b>Cleaning</b>	No high pressure
<b>Ambient temperature [°C   °F]</b>	0 to +40   +32 to +104
<b>Relative humidity level [%]</b>	95 (free of condensation)
<b>Mounting position</b>	Floor, Ceiling, Wall (on request), Angle (on request)

\* All given values are nominal values (nominal payload referred to a nominal performance) and can vary under realworld conditions depending on the application (tool specifications, load distances, reduction (partly) of the nominal performance when using food-grade lubricants, ...). Please consider our technical data sheets regarding the load capacity.