

## HHD DELTA RL4-1600-6kg

Article number: A\_00713-FO

Lubricant variant: Food-grade lubricants (FO)

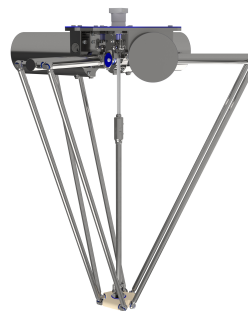

### Description:

This type of robot is based on the principle of parallel kinematics. All drives are mounted in a fixed position on the robot head. Motor cables are not moved. The robot has three (3) translational and one (1) rotational degree(s) of freedom.

### Scope of delivery:

Robot mechanics incl. gearbox, Servo motor adapter, Transport and packing instructions

### Connecting dimensions:

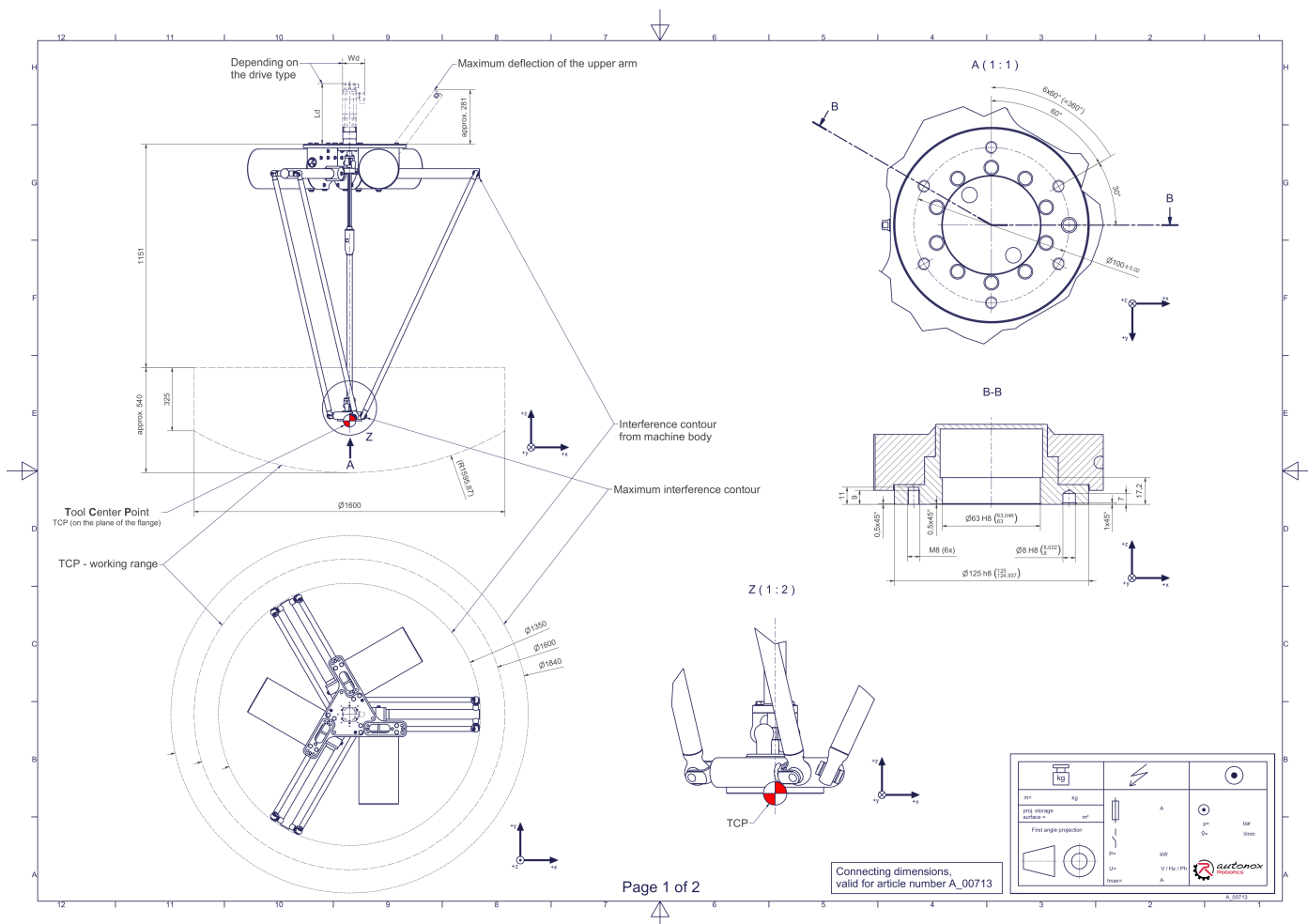

Downloads: [Connecting dimensions \(PDF\)](#), [3D model \(STP\)](#), [3D model \(PDF\)](#)

We refer to our [General Terms of Sale and Supply](#), [Terms of use](#) and [Disclaimer and Copyright notices](#).

© 2023 autonox Robotics GmbH | [www.autonox.com](http://www.autonox.com)

## Technical specifications:

<b>Field of application</b>	Hygienic 'HHD'
<b>Kinematics</b>	Parallel
<b>Translatory Degrees of Freedom (X,Y,Z)</b>	3
<b>Rotational Degrees of Freedom (<math>\alpha, \beta, \gamma</math>)</b>	1
<b>Nominal payload [kg   lbs] *</b>	6   13.2
<b>Working area-diameter [mm   in]</b>	1600   63.0
<b>Working height outside [mm   in]</b>	325   12.8
<b>Working height center [mm   in]</b>	540   21.3
<b>Max. acceleration torque of the rotation <math>\gamma</math> around Z at the output [Nm   in.lbs]</b>	28   247.8
<b>Nominal torque of the rotation <math>\gamma</math> around Z at the output [Nm   in.lbs]</b>	15,2   134.5
<b>Max. speed of the rotation <math>\gamma</math> around Z at the output [1/min]</b>	500
<b>Nominal speed of the rotation <math>\gamma</math> around Z at the output [1/min]</b>	430
<b>Bearing type of the telescopic shaft(s)</b>	Roller bearing
<b>Bearing type of the arm joints</b>	Roller bearing
<b>Lubricants of the bearings</b>	Food-grade (FO)
<b>Lubricants of the gearboxes</b>	Food-grade (FO)
<b>Cleaning</b>	Up to 28 bar   406 psi high pressure
<b>Protection class</b>	IP69K
<b>Ambient temperature [°C   °F]</b>	0 to +40   +32 to +104
<b>Relative humidity level [%]</b>	95 (free of condensation)
<b>Mounting position</b>	Ceiling, Wall (on request), Angle (on request)

\* All given values are nominal values (nominal payload referred to a nominal performance) and can vary under realworld conditions depending on the application (tool specifications, load distances, reduction (partly) of the nominal performance when using food-grade lubricants, ...). Please consider our technical data sheets regarding the load capacity.