

## DELTA RL4-600-1kg

Article number: A\_00082-04

Lubricant variant: Synthetic lubricants



### Description:

This type of robot is based on the principle of parallel kinematics. All drives are mounted in a fixed position on the robot head. Motor cables are not moved. The robot has three (3) translational and one (1) rotational degree(s) of freedom.

### Scope of delivery:

Robot mechanics incl. gearbox, Servo motor adapter, Threaded protection caps, Transport and packing instructions

### Connecting dimensions:

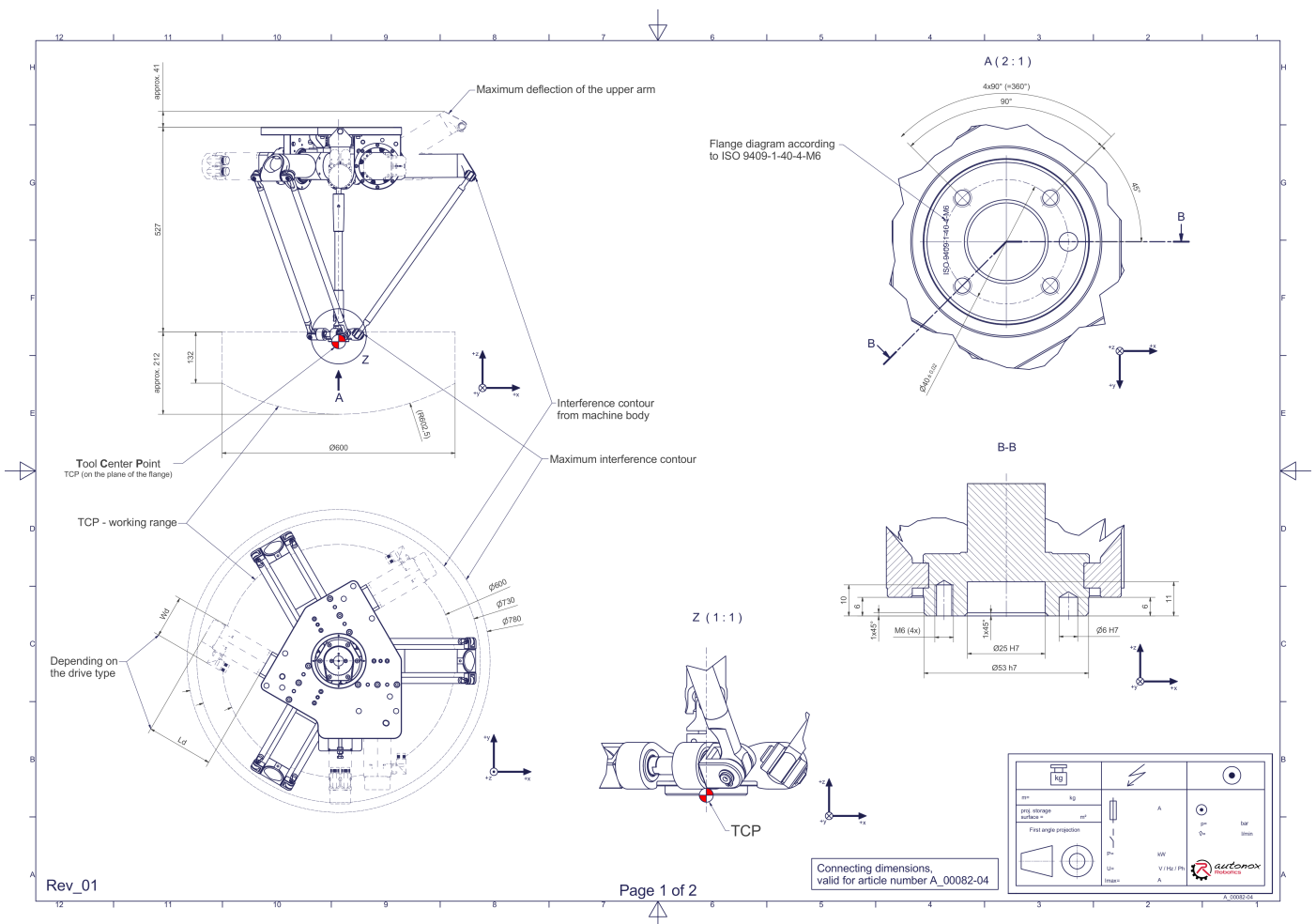

**Downloads:** [Connecting dimensions \(PDF\)](#), [3D model \(STP\)](#), [3D model \(PDF\)](#)

We refer to our [General Terms of Sale and Supply](#), [Terms of use](#) and [Disclaimer and Copyright notices](#).

## Technical specifications:

Field of application	Standard (not hygienic)
Kinematics	Parallel
Translatory Degrees of Freedom (X,Y,Z)	3
Rotational Degrees of Freedom ( $\alpha, \beta, \gamma$ )	1
Nominal payload [kg   lbs] *	1   2.2
Working area-diameter [mm   in]	600   23.6
Working height outside [mm   in]	132   5.2
Working height center [mm   in]	212   8.3
Max. acceleration torque of the rotation $\gamma$ around Z at the output [Nm   in.lbs]	7,2   63.7
Nominal torque of the rotation $\gamma$ around Z at the output [Nm   in.lbs]	7,2   63.7
Max. speed of the rotation $\gamma$ around Z at the output [1/min]	500
Nominal speed of the rotation $\gamma$ around Z at the output [1/min]	320
Bearing type of the telescopic shaft(s)	Roller bearing
Bearing type of the arm joints	Roller bearing
Lubricants of the bearings	Synthetic
Lubricants of the gearboxes	Synthetic
Cleaning	No high pressure
Ambient temperature [°C   °F]	0 to +40   +32 to +104
Relative humidity level [%]	95 (free of condensation)
Mounting position	Floor, Ceiling, Wall (on request), Angle (on request)
Robot weight without drive engineering (esp. drive) [kg   lbs]	26   57.3
Special features	All drives (gearbox, reduction gearing, ...) are located below the head plate. Advantages: Easily accessible, easy to maintain, compact

\* All given values are nominal values (nominal payload referred to a nominal performance) and can vary under realworld conditions depending on the application (tool specifications, load distances, reduction (partly) of the nominal performance when using food-grade lubricants, ...). Please consider our technical data sheets regarding the load capacity.

## Gearbox article number for this robot mechanics:

Function	Article number	Document
Drive of the upper arms	MT_BGR00009592-xx	Operating manual gearbox type 3 (PDF)
Drive of the telescopic shaft for rotation $\gamma$ around Z	MT_BGR00011502-xx	Operating manual gearbox type 1 (PDF)

We refer to our [General Terms of Sale and Supply](#), [Terms of use](#) and [Disclaimer and Copyright notices](#).