

## DELTA RL4-T1-1600-20kg

Article number: A\_00067-T1

Lubricant variant: Synthetic lubricants



### Description:

This type of robot is based on the principle of parallel kinematics. All drives are mounted in a fixed position on the robot head. Motor cables are not moved. The robot has three (3) translational and one (1) rotational degree(s) of freedom.

### Scope of delivery:

Robot mechanics incl. gearbox, Servo motor adapter, Threaded protection caps, Transport and packing instructions

### Connecting dimensions:

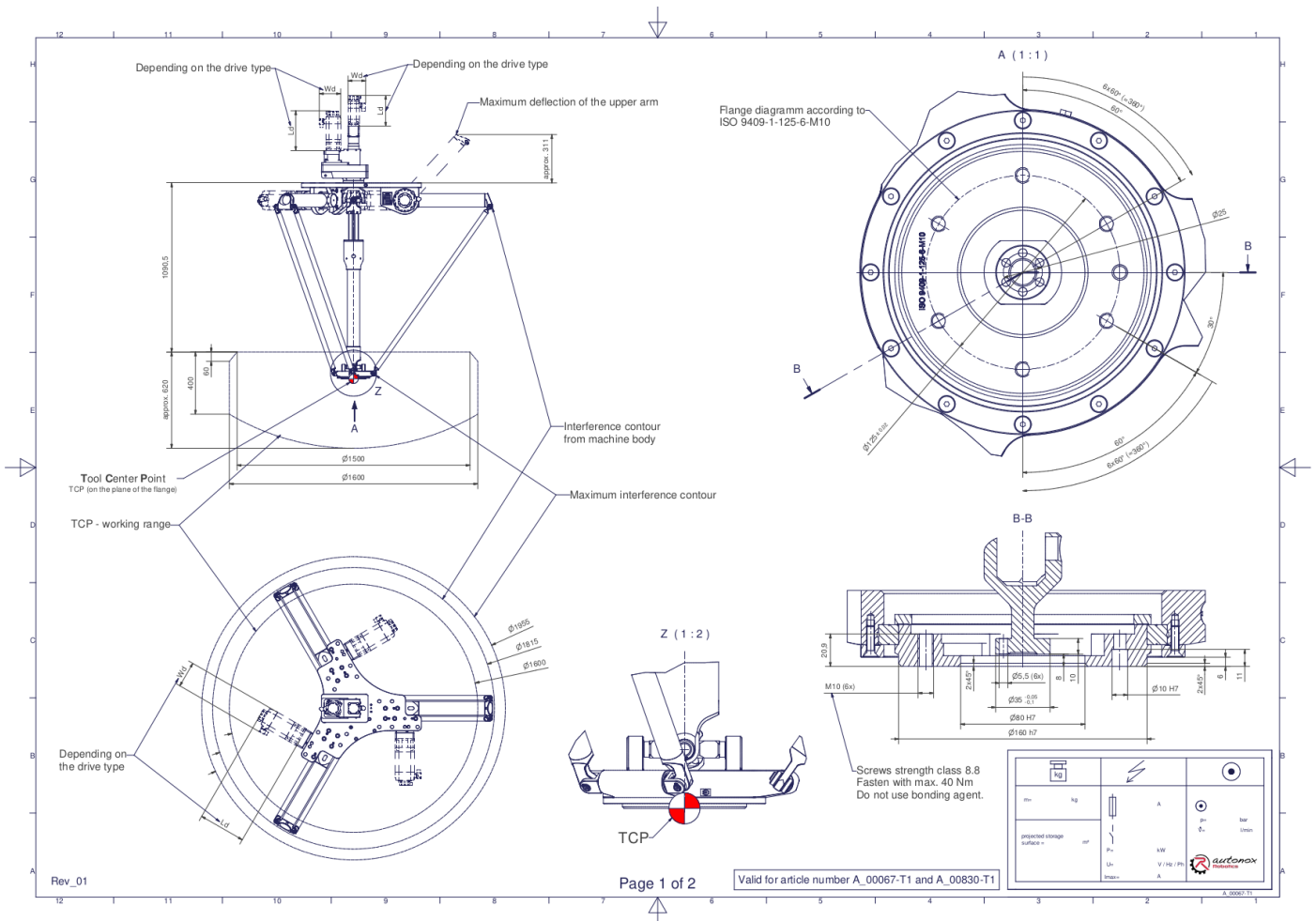

**Downloads:** [Connecting dimensions \(PDF\)](#), [3D model \(STP\)](#), [3D model \(PDF\)](#)

We refer to our [General Terms of Sale and Supply](#), [Terms of use](#) and [Disclaimer and Copyright notices](#).

## Technical specifications:

Field of application	Standard (not hygienic)
Kinematics	Parallel
Translatory Degrees of Freedom (X,Y,Z)	3
Rotational Degrees of Freedom ( $\alpha, \beta, \gamma$ )	1
Nominal payload [kg   lbs] *	20   44.1
Working area-diameter [mm   in]	1600   63.0
Working height outside [mm   in]	400   15.7
Working height center [mm   in]	620   24.4
Output type of the tool actuation	Flange (T)
Number of the tool actuation (telescopic shaft(s))	1
Max. acceleration torque of the rotation $\gamma$ around Z at the output [Nm   in.lbs]	240   2124.2
Nominal torque of the rotation $\gamma$ around Z at the output [Nm   in.lbs]	240   2124.2
Max. speed of the rotation $\gamma$ around Z at the output [1/min]	177
Nominal speed of the rotation $\gamma$ around Z at the output [1/min]	124
Max. acceleration torque of the tool actuation T/TS1 at the output [Nm   in.lbs]	40   354.0
Nominal torque of the tool actuation T/TS1 at the output [Nm   in.lbs]	23   203.6
Max. speed of the tool actuation T/TS1 at the output [1/min]	171
Nominal speed of the tool actuation T/TS1 at the output [1/min]	114
Bearing type of the telescopic shaft(s)	Roller bearing
Bearing type of the arm joints	Roller bearing
Lubricants of the bearings	Synthetic
Lubricants of the gearboxes	Synthetic
Cleaning	No high pressure
Ambient temperature [°C   °F]	0 to +40   +32 to +104
Relative humidity level [%]	95 (free of condensation)
Mounting position	Floor, Ceiling, Wall (on request), Angle (on request)
Robot weight without drive engineering (esp. drive) [kg   lbs]	124   273.4

\* All given values are nominal values (nominal payload referred to a nominal performance) and can vary under realworld conditions depending on the application (tool specifications, load distances, reduction (partly) of the nominal performance when using food-grade lubricants, ...). Please consider our technical data sheets regarding the load capacity.

**Gearbox article number for this robot mechanics:**

Function	Article number	Document
Drive of the upper arms	MT_BGR00017292-U-xx	Operating manual gearbox type 3 (PDF)
Drive of the telescopic shaft for rotation $\gamma$ around Z	MT_BGR00018858-xx	Operating manual gearbox type 7 (PDF)
Drive of the telescopic shaft for tool actuation T/TS1	MT_WST00058592-xx	Operating manual gearbox type 6 (PDF)