

## DELTA RL3-T1-1600-20kg

Article number: A\_00066-T1

Lubricant variant: Synthetic lubricants



### Description:

This type of robot is based on the principle of parallel kinematics. All drives are mounted in a fixed position on the robot head. Motor cables are not moved. The robot has three (3) translational degrees of freedom.

### Scope of delivery:

Robot mechanics incl. gearbox, Servo motor adapter, Threaded protection caps, Transport and packing instructions

### Connecting dimensions:

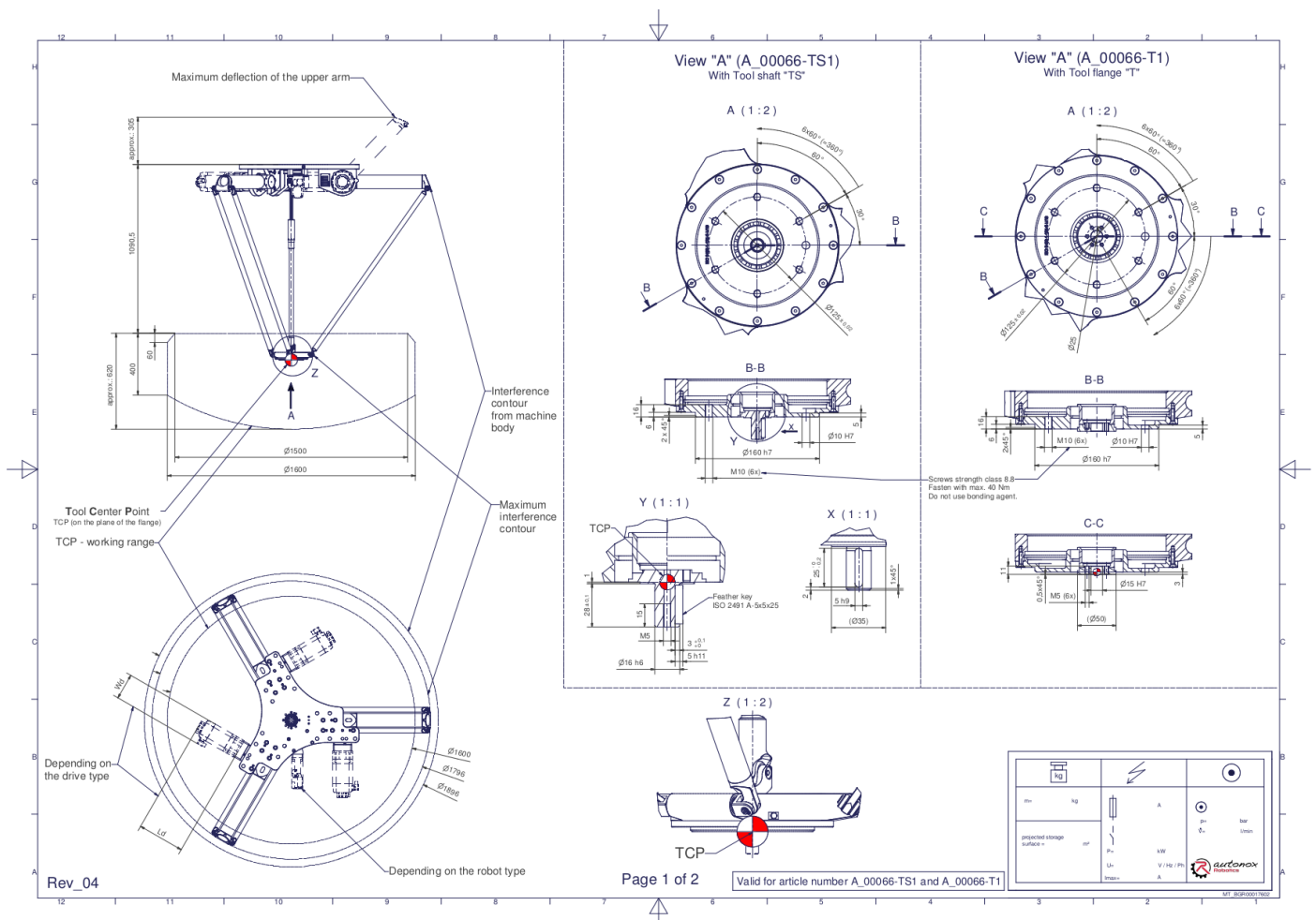

**Downloads:** [Connecting dimensions \(PDF\)](#), [3D model \(STP\)](#), [3D model \(PDF\)](#)

We refer to our [General Terms of Sale and Supply](#), [Terms of use](#) and [Disclaimer and Copyright notices](#).

## Technical specifications:

<b>Field of application</b>	Standard (not hygienic)
<b>Kinematics</b>	Parallel
<b>Translatory Degrees of Freedom (X,Y,Z)</b>	3
<b>Rotational Degrees of Freedom (<math>\alpha,\beta,\gamma</math>)</b>	0
<b>Nominal payload [kg lbs] *</b>	20   44.1
<b>Working area-diameter [mm in]</b>	1600   63.0
<b>Working height outside [mm in]</b>	400   15.7
<b>Working height center [mm in]</b>	620   24.4
<b>Output type of the tool actuation</b>	Flange (T)
<b>Number of the tool actuation (telescopic shaft(s))</b>	1
<b>Max. acceleration torque of the tool actuation T/TS1 at the output [Nm in.lbs]</b>	40   354.0
<b>Nominal torque of the tool actuation T/TS1 at the output [Nm in.lbs]</b>	33   292.1
<b>Max. speed of the tool actuation T/TS1 at the output [1/min]</b>	225
<b>Nominal speed of the tool actuation T/TS1 at the output [1/min]</b>	150
<b>Bearing type of the telescopic shaft(s)</b>	Roller bearing
<b>Bearing type of the arm joints</b>	Roller bearing
<b>Lubricants of the bearings</b>	Synthetic
<b>Lubricants of the gearboxes</b>	Synthetic
<b>Cleaning</b>	No high pressure
<b>Ambient temperature [°C °F]</b>	0 to +40   +32 to +104
<b>Relative humidity level [%]</b>	95 (free of condensation)
<b>Mounting position</b>	Floor, Ceiling, Wall (on request), Angle (on request)

\* All given values are nominal values (nominal payload referred to a nominal performance) and can vary under realworld conditions depending on the application (tool specifications, load distances, reduction (partly) of the nominal performance when using food-grade lubricants, ...). Please consider our technical data sheets regarding the load capacity.