

DELTA RL3-T1-1400-6kg

Article number: A_00055-T1

Lubricant variant: Synthetic lubricants



Description:

This type of robot is based on the principle of parallel kinematics. All drives are mounted in a fixed position on the robot head. Motor cables are not moved. The robot has three (3) translational degrees of freedom.

Scope of delivery:

Robot mechanics incl. gearbox, Servo motor adapter, Threaded protection caps, Transport and packing instructions

Connecting dimensions:

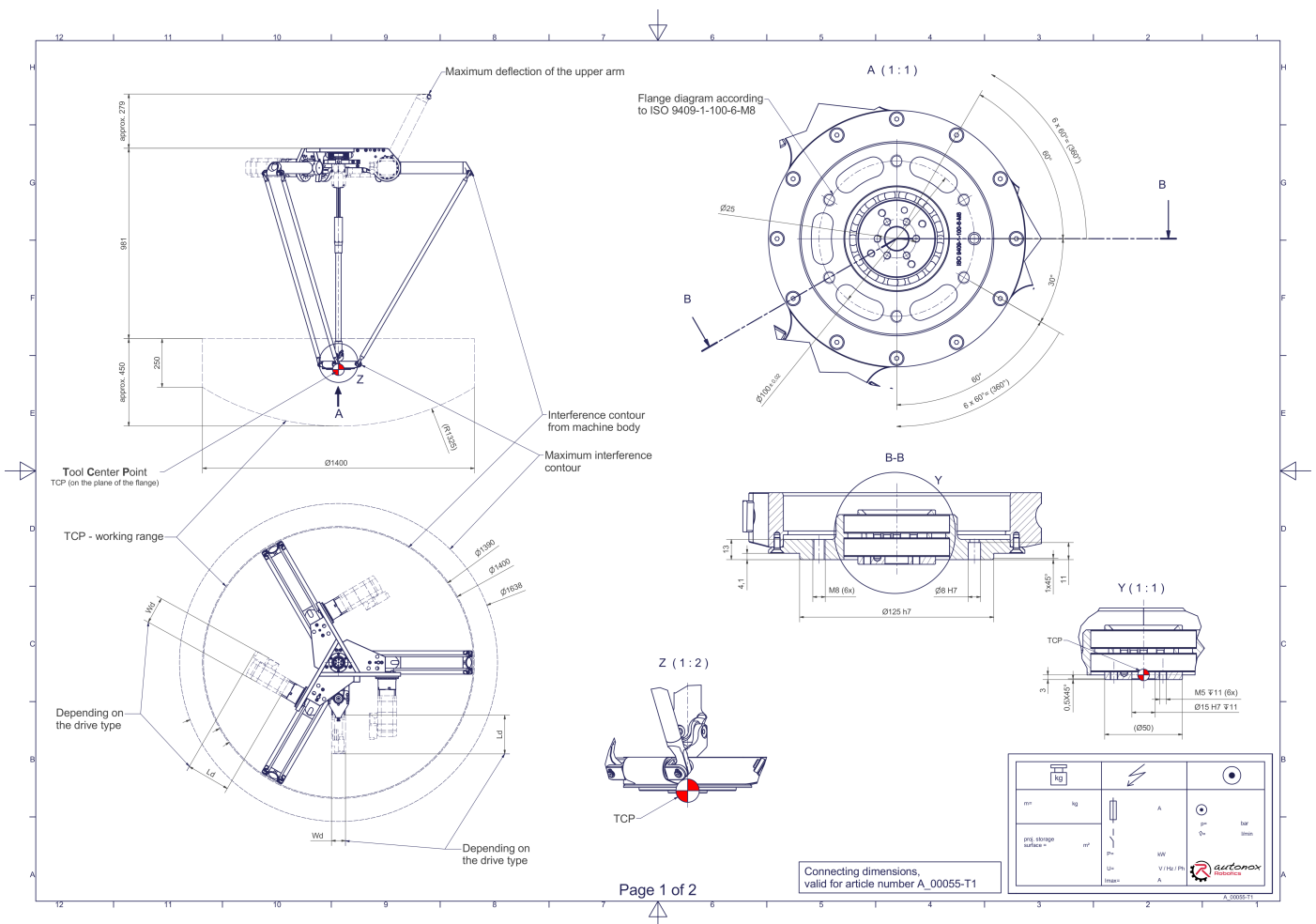

Downloads: [Connecting dimensions \(PDF\)](#), [3D model \(STP\)](#), [3D model \(PDF\)](#)

We refer to our [General Terms of Sale and Supply](#), [Terms of use](#) and [Disclaimer and Copyright notices](#).

Technical specifications:

Field of application	Standard (not hygienic)
Kinematics	Parallel
Translatory Degrees of Freedom (X,Y,Z)	3
Rotational Degrees of Freedom (α, β, γ)	0
Nominal payload [kg lbs] *	6 13.2
Working area-diameter [mm in]	1400 55.1
Working height outside [mm in]	250 9.8
Working height center [mm in]	450 17.7
Output type of the tool actuation	Flange (T)
Number of the tool actuation (telescopic shaft(s))	1
Max. acceleration torque of the tool actuation T/TS1 at the output [Nm in.lbs]	40 354.0
Nominal torque of the tool actuation T/TS1 at the output [Nm in.lbs]	33 292.1
Max. speed of the tool actuation T/TS1 at the output [1/min]	225
Nominal speed of the tool actuation T/TS1 at the output [1/min]	150
Bearing type of the telescopic shaft(s)	Roller bearing
Bearing type of the arm joints	Roller bearing
Lubricants of the bearings	Synthetic
Lubricants of the gearboxes	Synthetic
Cleaning	No high pressure
Ambient temperature [°C °F]	0 to +40 +32 to +104
Relative humidity level [%]	95 (free of condensation)
Mounting position	Floor, Ceiling, Wall (on request), Angle (on request)
Robot weight without drive engineering (esp. drive) [kg lbs]	41 90.4

* All given values are nominal values (nominal payload referred to a nominal performance) and can vary under realworld conditions depending on the application (tool specifications, load distances, reduction (partly) of the nominal performance when using food-grade lubricants, ...). Please consider our technical data sheets regarding the load capacity.

Gearbox article number for this robot mechanics:

Function	Article number	Document
Drive of the upper arms	MT_BGR00013366-xx	Operating manual gearbox type 3 (PDF)
Drive of the telescopic shaft for tool actuation T/TS1	MT_BGR00013360-xx	Operating manual gearbox type 1 (PDF)

We refer to our [General Terms of Sale and Supply](#), [Terms of use](#) and [Disclaimer and Copyright notices](#).