

DELTA RL5-1350-1kg

Article number: AL_00106



Description:

This type of robot is based on the principle of parallel kinematics. All drives are mounted in a fixed position on the robot head. Motor cables are not moved. The robot has three (3) translational and two (2) rotational degrees of freedom. This robot mechanics is characterized by its attractive pricing. Due to the joint design, the nominal payload is limited and the average performance and/or lifetime is reduced compared to classic autonox mechanics. The robot is delivered in pre-assembled main assemblies to save space.

Scope of delivery:

Robot mechanics incl. gearbox, Servo motor adapter, Threaded protection caps, Transport and packing instructions

Connecting dimensions:

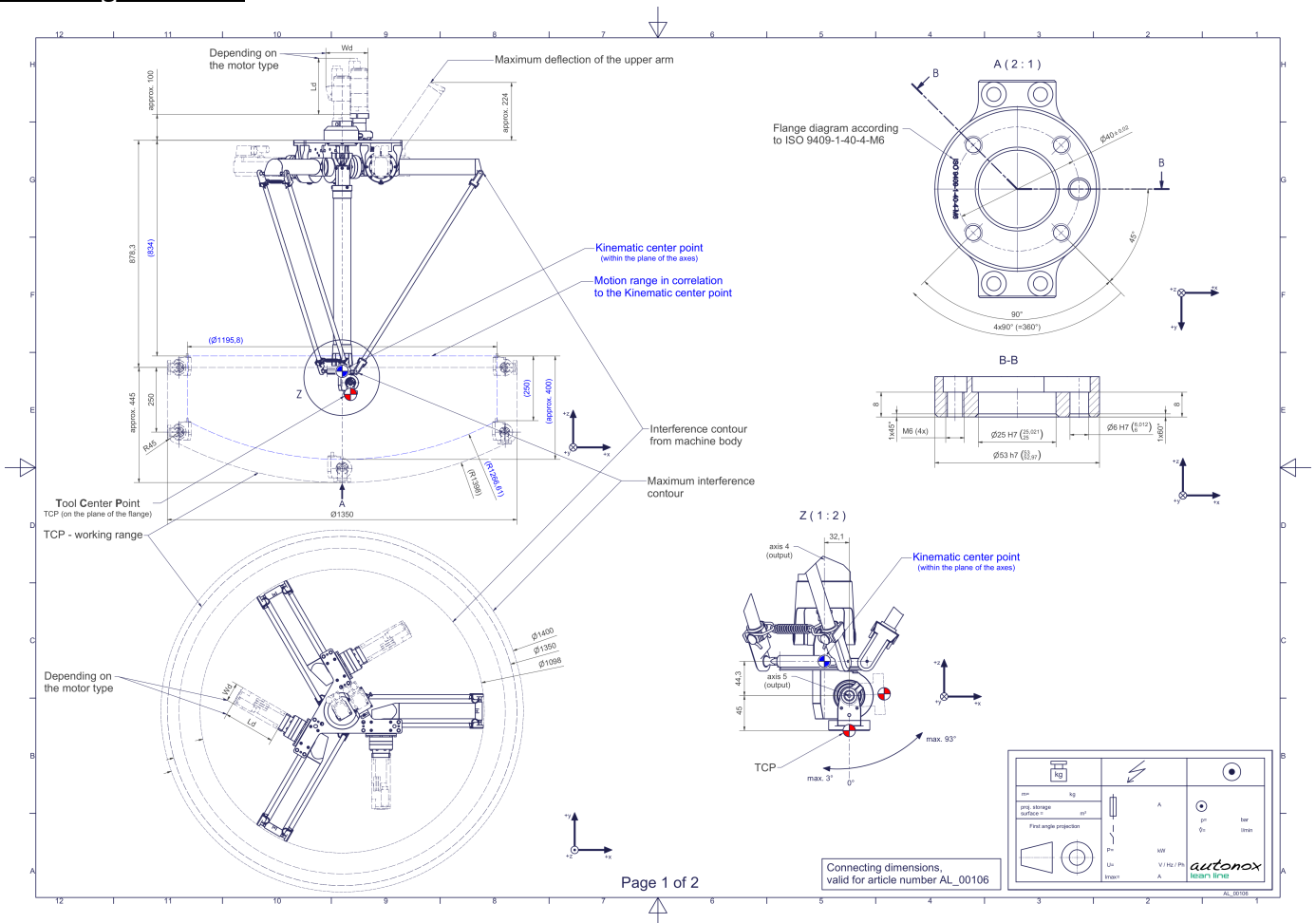

Downloads: [Connecting dimensions \(PDF\)](#), [3D model \(STP\)](#), [3D model \(PDF\)](#)

We refer to our [General Terms of Sale and Supply](#) and [Terms of use](#).

Technical specifications:

Field of application	Standard (not hygienic)
Kinematics	Parallel
Translatory Degrees of Freedom (X,Y,Z)	3
Rotational Degrees of Freedom (α,β,γ)	2
Nominal payload [kg lbs] *	1 2.2
Working area-diameter [mm in]	1350 53.1
Working height outside [mm in]	250 9.8
Working height center [mm in]	445 17.5
Max. acceleration torque of the rotation α/β around X/Y at the output [Nm in.lbs]	16 141.6
Nominal torque of the rotation α/β around X/Y at the output [Nm in.lbs]	16 141.6
Max. speed of the rotation α/β around X/Y at the output [1/min]	124
Nominal speed of the rotation α/β around X/Y at the output [1/min]	124
Max. acceleration torque of the rotation γ around Z at the output [Nm in.lbs]	7,2 63.7
Nominal torque of the rotation γ around Z at the output [Nm in.lbs]	7,2 63.7
Max. speed of the rotation γ around Z at the output [1/min]	500
Nominal speed of the rotation γ around Z at the output [1/min]	400
Bearing type of the telescopic shaft(s)	Roller bearing: rotation α/β around X/Y; Journal bearing: rotation γ around Z
Bearing type of the arm joints	Journal bearing
Lubricants of the bearings	Food-grade (FO)
Lubricants of the gearboxes	Food-grade (FO)
Cleaning	No high pressure
Ambient temperature [°C °F]	0 to +40 +32 to +104
Relative humidity level [%]	95 (free of condensation)
Mounting position	Floor, Ceiling, Wall (on request), Angle (on request)

* All given values are nominal values (nominal payload referred to a nominal performance) and can vary under realworld conditions depending on the application (tool specifications, load distances, reduction (partly) of the nominal performance when using food-grade lubricants, ...). Please consider our technical data sheets regarding the load capacity.

Gearbox article number for this robot mechanics:

Function	Article number	Document
Drive of the upper arms	MT_WST00108764-xx-FO	Operating manual gearbox type 3 (PDF)
Drive of the telescopic shaft for rotation γ around Z	MT_WST00117060-xx-FO	Operating manual gearbox type 1 (PDF)

We refer to our [General Terms of Sale and Supply](#) and [Terms of use](#).